



# Water Bath LPG Vaporizers

with "Smart" Liquid Carryover Protection

## 08-Series



WB-458 in standard Configuration

## 05-Series



WB-2505 with standard Extended Control Room (Maintenance House)

- Capacities 168 gph to 10000 gph (322 kg/h to 20 metric tons per hour)
  - For Propane, Butane, and other LPG
  - Forced Draft Power Burners
  - Low-Fire/High-Fire Modulation
  - Small Footprint, High Efficiency
  - Conforms to ASME, NFPA, PED/CE
  - FM approved, CE Mark available
  - Heavy-Gauge Steel Construction
  - All-Welded Design
  - Step-in Control Room for small models
  - Walk-in Control Room for larger models
  - PLC Controls with First-Out Monitor
  - Color LCD Touch Screen
- Many Standard Options:
    - ⇒ Extended Control Room (Maintenance House)
    - ⇒ Remote Monitoring and Operation (Ethernet) via Web Browser
    - ⇒ Integration with LPG/Air Mixers for Standby Systems and PeakShaving Systems
    - ⇒ Siemens or Allen-Bradley PLC
    - ⇒ High-Pressure up to 400 psi
    - ⇒ Integration into Plant Monitoring
    - ⇒ Wireless Access
    - ⇒ Multi-Language Operator Interface
    - ⇒ Control Room with Heater and A/C

# What are LPG Vaporizers ?

**L**PG vaporizers are actually boilers. Instead of boiling water, they boil propane, butane, or another LPG (Liquefied Petroleum Gas). It may sound strange that heat is required to vaporize LPG when Propane will boil at -44°F (-42°C) and Butane at 32°F (0°C), but, when LPG vaporizes by expansion alone, it causes a refrigeration action. In applications with high LPG flow, the uncontrolled vaporization could freeze pipe, valves, regulators, and even burner nozzles. Therefore, controlled heat input is required to offset the refrigeration action.

## Standard Features and Options 05-Series and 08-Series

- Multi-Pass Steel Burner Tube.
- Multi-Pass High-Efficiency LPG Vapor Tube with welded heat transfer fins, rated for 250 psig @ 650 °F.
- Designed and manufactured per ASME Pressure Vessel Code, Section VIII, Division 1, and latest edition of NFPA 58.
- Fully Integrated Power Burner with Honeywell Electronic Flame Safeguard.
- Water Circulation Pump with internal Diffuser.
- All models are FM approved. CE Approval available.
- “Smart” Liquid Carryover Protection.
- UL listed Safety Pressure Relief Valve.
- UL listed Solenoid Valve (Liquid Inlet).
- Safety Controller for Performance Level 4 (SIL 3)
- Vaporizer Control Panel with PLC, Electronic Operator Interface with color LCD display and Touch Screen; First-Out Monitor; TrendLine recording and Alarm History in real time and on SD-Card with storage space for 2+ years; remote access via Ethernet/Internet standard on all models.
- Electronic Thermostat with multi-point burner modulation standard on all 05-Series models.
- Factory Primed, Painted, and Tested.

### Options:

- ASME “U” Stamp for Vaporization Tubes
- High-Pressure Heat Exchanger
- Custom Control Panels and System Integration
- Wireless Remote Monitoring and Control
- Remote Monitoring and Control via cell phone
- Control Panel with UL 508 A certification or CE Mark
- Large-Screen Operator Interface



Standard Control Panel with Siemens S7-1200 PLC, Safety Controller, automatic circuit breakers, Ethernet Router, and Honeywell Flame Safeguard.

## Applications

**A**ES Water Bath Vaporizers have been manufactured since 1974 and have seen continuous design improvement. This has led to probably the most versatile and most reliable line of Water Bath Vaporizers on the market today. AES currently manufactures the 08-Series for capacities from 168 gph (322 kg/h) to 508 gph (1000 kg/h); and the 05-Series for capacities from 455 gph (873 kg/h) to 10000 gph (20 metric tons per hour).

Installations around the world include Peak Shaving Plants for Gas Utilities, Standby Plants for large industrial users, Backup Systems for government and defense installations, Primary Fuel Source for areas without natural gas supply or for areas preparing for connection to natural gas, Power Plants, Glass and Brick Manufacturing, Chemical Plants, Food Processing, etc.

AES Water Bath Vaporizers can be used “stand-alone”, or in combination with LPG/Air mixing systems, producing Synthetic Natural Gas (SNG) that is directly interchangeable with natural gas.

# How do Alternate Energy Systems' Water Bath Vaporizers work ?

**W**ater Bath Vaporizers are available in standard capacities from 168 gallons per hour (gph), to 10,000 gph. From the outside, they differ primarily in their size. Inside, the burner capacity, the amount of heat exchange medium, and the active heat exchange areas of the vapor tube and the burner tube also determine their vaporization capacity.

The drawing below shows a typical configuration of a 1000 gph vaporizer. The main components of the vaporizer are the Burner Tube (D) with the Exhaust Stack (A), the Vapor Tube (B) with Welded Fins (C), the Steel Shell (K) with the integral Burner and Control Room (Q), the Liquid Inlet Train (F, G, I, J), the Vapor Outlet Header (E) with "Smart" Liquid Carryover Protection (K, L), and the Gas Train (H, W) for the Power Burner (Z).

Also shown on the drawing are the Water Tank Insulation (O), the Outer Sheet Metal Shell (N), the Vaporizer Control Panel (T), the Main Fuel Gas Valve (W), the Water Circulation Pump (U), and the controls for Water Bath Temperature (X) and Low Water Level (R).

The Burner Tube and the Vapor Tube are fully immersed in a heat transfer solution (water/anti-freeze). LPG vapor from naturally occurring vaporization is taken from the Vapor Outlet Header (E) and fed through a Pressure Regulator (H) to the Burner (Z). The Burner heats the heat transfer solution through the Burner Tube (D). Adjustable temperature controls (X) maintain a constant water temperature. The heat from the water is transferred through the Vapor Tube (B) to the LPG, which then evaporates and exits the system through the Vapor Outlet Header (E). The Sensor of a Temperature Transmitter (K) is inserted deep into the Vapor Outlet Header (E). Its signal is processed together with the signal from a dedicated pressure transmitter (L) by the "smart" Liquid Carryover protection function. "Smart" constantly compares the pressure and temperature signals against the vapor pressure/temperature saturation curve of the LPG that is being vaporized. The properties of the LPG (Propane/Butane percentage), and the "safety margin" (how close the pressure/temperature are allowed to come to the saturation curve) can be entered through the operator interface. If the safety margin is "breached", the liquid inlet valve (J) is closed after an adjustable alarm delay period has elapsed. This prevents liquid from being carried over to the distribution system.

The signal from the vapor temperature transmitter is also used to keep the Liquid Inlet Valve closed until the LPG vapor at the vaporizer outlet has reached an adjustable minimum temperature.

Other components in the Liquid Inlet Train are the manual Liquid Shutoff Valve (F), the Strainer (G), and the Check Valve (I), allowing excess LPG pressure in the Vapor Tube to vent back through the liquid supply line into the storage tank.

The insulation of the water bath tank and the thorough corrosion protection allow the vaporizer to be installed outside without any further weather protection.

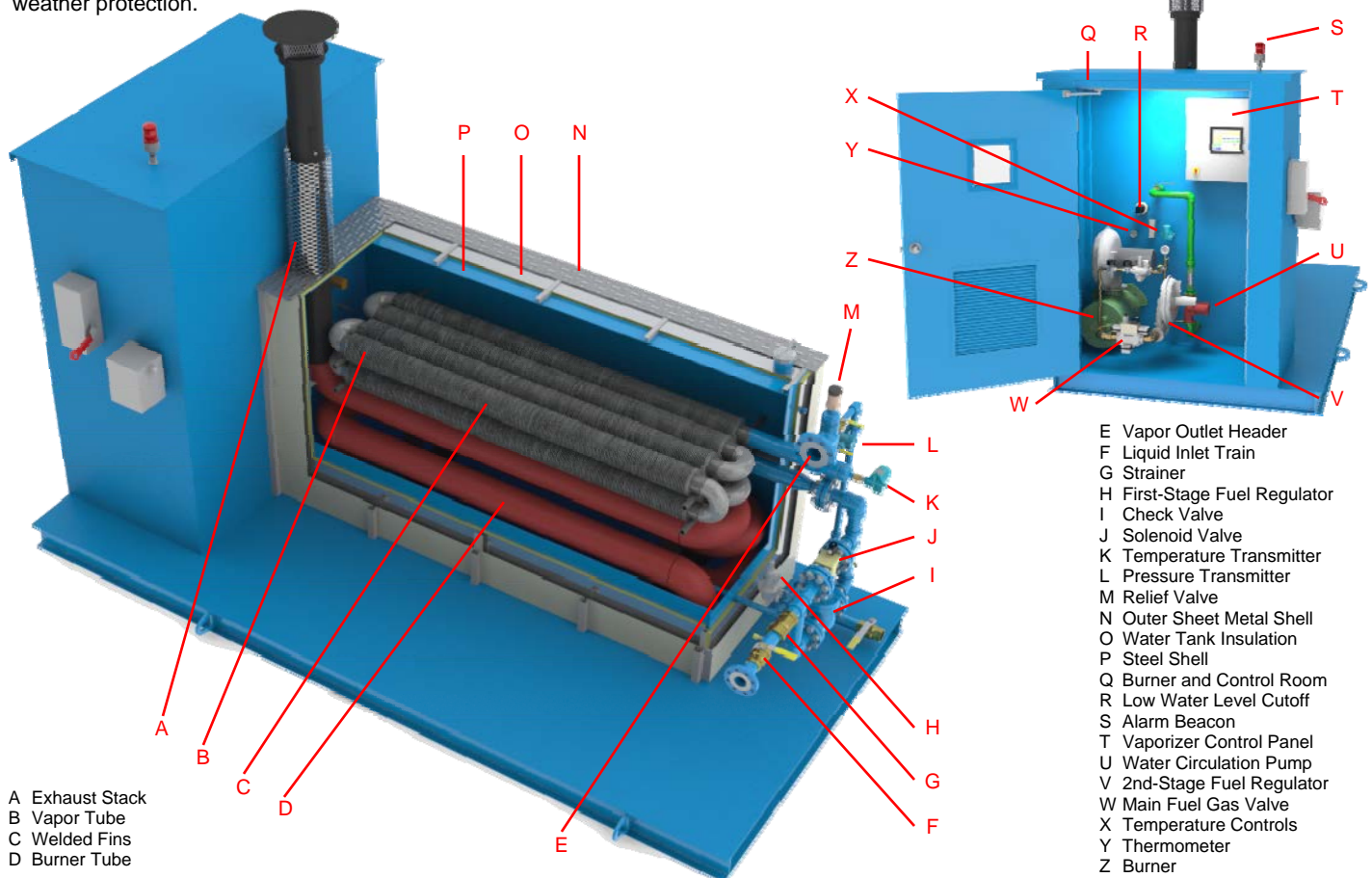

## Specifications - 08-Series - WB-168 to WB-508

Standard Specifications		WB-168	WB-208	WB-258	WB-308	WB-358	WB-408	WB-458	WB-508																				
Nominal Vaporization Capacity <sup>1</sup>	gph	168	208	258	308	358	408	458	508																				
	kg/h	322	399	495	585	687	783	879	975																				
	MMBTU/h	15.5	19.1	23.7	28.1	32.9	37.5	42.1	46.8																				
	kcal/h x 10 <sup>6</sup>	3.9	4.8	6.0	7.1	8.3	9.5	10.6	11.8																				
Water Tank Capacity	gal	165 to Fill Plug																											
	m <sup>3</sup>	0.625 to Fill Plug																											
Burner Capacity	MMBTU/h	0.200	0.250	0.310	0.370	0.430	0.490	0.550	0.610																				
	kW	59	73	91	108	126	144	161	179																				
Burner Type		Compact Forced-Draft Power Burner, fully integrated; DUNGS Main Gas Valve with PoC																											
Design Temperature	°F	650																											
	°C	343																											
Design Pressure	psi	250																											
	bar	17.2																											
Standard Safety Features		<p>Honeywell 7800-Series; PLC Input with Status Indication at Operator Interface; Alarm History.</p> <p>All Burner Safety Interlocks, GasLeak Monitor contacts, and ESD circuits are connected to inputs at the agency-approved Safety Controller (Phoenix Contact PSR Tri-Safe). The Safety Controller energizes agency-approved expansion relays only if all safety circuits are "okay".</p> <p>The expansion relays supply control power to the outputs of the PLC. If the Safety Controller detects a problem, the expansion relays are de-energized, effectively taking control power away from the outputs of the PLC.</p> <p>This configuration makes the safety functions independent from the general-purpose PLC and elevates the safety classification of the vaporizer control system to Performance Level 4 (formerly known as SIL 3).</p> <p>The Safety Status is indicated at the Operator Interface and recorded in the Alarm History.</p>																											
Electronic Flame Safe Guard		<p>"Smart"; Press. and Temp. transmitter in Vapor Outlet; selectable LPG Type; adjustable Safety Margin; Alarm History.</p> <table border="1" style="width: 100%; border-collapse: collapse;"> <tr> <td>X</td><td>X</td><td>X</td><td>X</td><td>X</td><td>X</td><td>X</td><td>X</td><td>X</td><td>X</td> </tr> <tr> <td>X</td><td>X</td><td>X</td><td>X</td><td>X</td><td>X</td><td>X</td><td>X</td><td>X</td><td>X</td> </tr> </table>								X	X	X	X	X	X	X	X	X	X	X	X	X	X	X	X	X	X	X	X
X	X									X	X	X	X	X	X	X	X												
X	X									X	X	X	X	X	X	X	X												
Low Burner Fuel Gas Pressure																													
High Burner Fuel Gas Pressure																													
Low Water Level Cutoff																													
High Bath Temperature Limit																													
GasLeak Monitor in Control Room	40% LEL																												
GasLeak Monitor in Control Room	Trouble																												
Dual E-Stop Circuits																													
Liquid Carryover Protection																													
Relief Valve for Vaporization Tubes																													
Relief Valve for Burner Gas Train																													
Liquid Inlet Connection		1-inch 300# Raised Face ANSI Flange (DN25 PN40 DIN Flange available at no additional charge)																											
Liquid Inlet Valve		1-inch 250 psi Flanged Solenoid Valve; 110/220 VAC; with Check Valve Bypass; Globe Valve for Manual Shutoff.																											
Vapor Outlet Connection		2-inch 300# Raised Face ANSI Flange (DN50 PN40 DIN Flange available at no additional charge)																											
PLC and Electronic Operator Interface (EOI)		<p>Siemens S7-1200 PLC with Ethernet Interface; high-resolution Color LCD Touch Screen (800x480); Ethernet Interface; 96-hr Trend Recording; Trend Data for 2 years is saved on standard SD card and can be displayed in Microsoft Excel format; Remote Access to built-in VNC Server allows Monitoring and Control of all Vaporizer Functions; unlimited license for VNC Client Software is included and can be installed on multiple Laptops or PCs.</p> <p>Allen-Bradley MicroLogix-1400 PLC with Ethernet Interface; high-resolution Color LCD Touch Screen (800x480); Ethernet Interface; 96-hr Trend Recording; Trend Data for 2 years is saved on standard SD card and can be displayed in Microsoft Excel format; Remote Access to built-in VNC Server allows Monitoring and Control of all Vaporizer Functions; unlimited license for VNC Client Software is included and can be installed on multiple Laptops or PCs.</p> <p>Contact AES for other PLC/EOI configurations (Siemens, Allen-Bradley, GE, Bristol-Babcock, ...)</p>																											
Electrical Requirements (other Voltages available)		110/220/230VAC 50/60Hz; 15A Circuit; 1-Phase; galvanically isolating step-up/step-down transformer included.																											
Circuit Protection		Automatic Circuit Breakers with Manual Reset for all AC and DC Circuits; Main Breaker/Disconnect.																											
Design Criteria		<p>Vaporizer: Designed and manufactured to comply with the latest edition of NFPA Pamphlet 58; FM approved. European CE Mark available (third-party examination by TÜV Rheinland / TÜV Süd).</p> <p>LPG Heat Exchanger: Designed and manufactured in compliance with Boiler and Pressure Vessel Code Section VIII, Division 1. ASME "U"-Stamp available. CE-marked vaporizers comply with European PED.</p> <p>Control Panel: General-purpose wiring, compliant with National Electric Code (NEC; NFPA #70). UL-508A available. CE-marked vaporizers comply with all applicable European Directives.</p>																											
Mechanical Construction		<p>Skid: 1/4-inch (6.35mm) Steel Deck Plate on all-welded 4-inch (100mm) Channel Frame with Cross-Members; Lifting Lugs; mechanically cleaned, primed, and painted (dark-gray, RAL 7043).</p> <p>Bath Box: 1/4-inch (6.35mm) all-welded steel walls with internal stiffeners and supports for LPG Heat Exchanger.</p> <p>Water Circulating Pump: Wet-Cartridge-Type Hot-Water Circulator installed inside Vaporizer Control Room; Diffuser in Water Bath.</p> <p>Insulation: Fiber board insulation with Aluminum backing on side walls, top plate, and rear wall.</p> <p>Bath Box Cover: 16-gauge (1.5mm) Sheet Metal, pre-formed, powder-coated (beige RAL 1015).</p> <p>Control Room: 16-gauge (1.5mm) Sheet Metal, pre-formed, powder-coated (beige RAL 1015); lockable double-door; window insert.</p>																											
Dimensions <sup>2</sup>	inches	Overall: 48(W) x 132(L) x 110(H) Control Room: 48(W) x 48(L) x 82(H) Shipping Height: 86 (removable exhaust)																											
	m	Overall: 1.22(W) x 3.35(L) x 2.79(H) Control Room 1.22(W) x 1.22(L) x 2.08(H) Shipping Height: 2.18m																											
Shipping Weight <sup>2</sup>		3700 lbs 1700 kg (can be shipped inside standard 20-ft ISO Container)																											

(1) Nominal Capacity for Vaporization of HD-5 @ 0°F (-18°C) Liquid Temperature

(2) Dimensions and weights are approximate

Specifications subject to change without notice

## Drawings, 08-Series

Full-Size Step-in Control Room on all 08-Series Models.

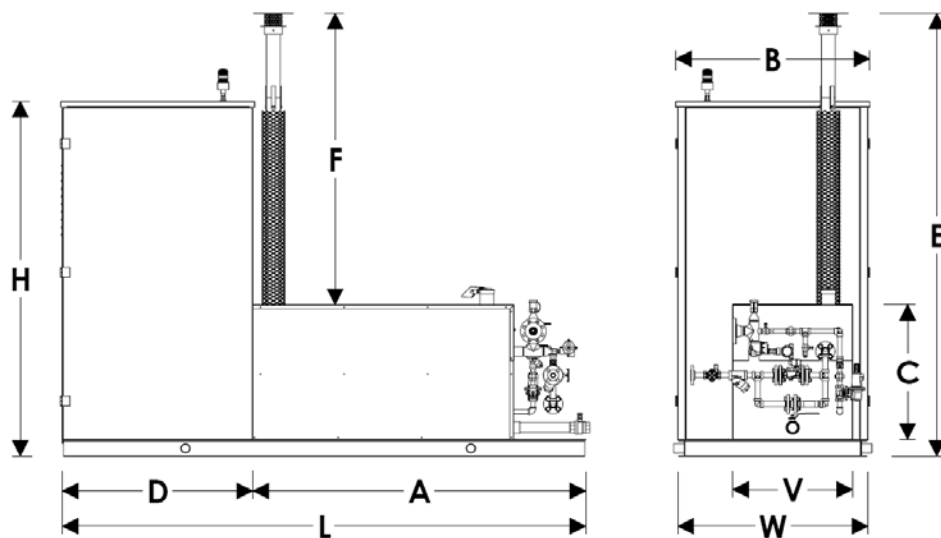

### Dimensions for all 08-Series Vaporizers with Full-Size Step-in Control Room

	W	L	H	V	A	B	C	D	E	F	Concrete Slab	
WB-168 to WB-508	inches	48	132	86	30	84	48	34	48	110	72	8' x 15'
	m	1.22	3.35	2.18	0.76	2.13	1.22	0.86	1.22	2.79	1.83	2.44m x 4.58m

### Cut-Away of a 08-Series Vaporizer



### Safety Controller for Performance Level 4 (SIL 3)

In recognition of already implemented international standards, and in anticipation of future US-requirements, all AES vaporizers of the 08-Series and the 05-Series are now equipped with Agency-approved Safety Controllers (per EN ISO 13849-1).

Safety Controllers are self-diagnosing, self-monitoring, dual-redundancy, multi-channel electronic devices that monitor inputs from fail-safe safety-circuits. If any of the monitored channels detects a problem, the output of the safety relay is immediately turned OFF.

In 08-Series and 05-Series vaporizers the outputs of all safety relays must be energized before the Burner can be started, or the Liquid Inlet Valve can open. If one or more outputs of the safety relays are de-energized while the Burner is operating, or while the Liquid Inlet Valve is open, the burner is stopped and the Liquid Inlet Valve is closed.

Two expansion relays provide independent control power to the outputs of the PLC for the burner controls, and for all other safety-related functions.

The use of Safety Controllers elevates the safety of AES vaporizers to "Performance Level 4" (SIL 3).



AES uses a Safety Controller manufactured by Phoenix Contact, and expansion relays from Pilz and other manufacturers that carry the required Agency-Approvals.

### GasLeak Monitors

All AES vaporizers of the 08-Series and the 05-Series are equipped with GasLeak Monitors (GLM) with long-life infrared sensors (expected sensor life 10+ years) in the Vaporizer Control Room. The GLM issue a Warning Alarm if gas levels above 20% LEL (Lower Explosive Limit) are detected. If the gas concentration reaches 40% LEL, or if the self-diagnostics of the GLM detect a sensor failure, a System Shutdown Alarm is issued.

All GLM have a full-graphic LED display that shows the current gas level and provides overall status information (see picture). The 05- and 08-Series vaporizers repeat the LEL display and the status of the alarm channels at the Electronic Operator Interface.

Alternate Energy Systems has selected the Emerson Millennium II as our standard GLM for its superior quality, reliability, ease-of-use and wide range of approvals (FM, CSA, ATEX, IECEx, INMETRO, ...). All setup and maintenance can be performed without opening the transmitter or declassifying a hazardous area through a "magnetic wand" (included).



The GLM communicates with the vaporizer controls by means of three static relay signals (40% LEL CH1; 40% LEL CH2; Sensor Trouble), and a 4-20mA analog signal (for on-screen LEL indication, and to notify the vaporizer controls that sensor-recalibration is required). If sensor-recalibration is required, the vaporizer EOI will display a warning message.

All menu items and messages are displayed in plain English (can also be switched to French, Portuguese or Spanish).

### LPG with High Butane Content or Low Liquid Temperature

The vaporization capacity of all vaporizers in this brochure is given for "HD-5" commercial Propane at 0°F (-18°C), for pressures up to 200 psi (14 bar).

If the lowest expected ambient temperature is below 0°F (-18°C), or if the Propane content in the LPG is less than 80%, more heat is required to vaporize the LPG.

When more heat is required for the desired vaporization rate, the burner capacity and the heat transfer area must both be increased. In most cases, our vaporizers can be re-configured without changing their physical dimensions.

Please make certain that you include all relevant operating parameters with your request for quotation. This includes LPG composition, lowest expected ambient temperature, and required discharge pressure.

Examples: Apprx. heat input to vaporize 1000 gal (2000 kg) LPG at 50 psi (3.5 bar) (Superheat 30°F / 16°C - Heat Exchanger Efficiency 80%)

Ambient (Liquid) Temperature	Burner Input	100/0 P/B	70/30 P/B	50/50 P/B	30/70 P/B	0/100 P/B
-40°F (-40°C)	MMBTU kWh	1.17 344	1.21 355	1.25 366	1.29 378	1.38 404
0°F (-18°C)	MMBTU kWh	1.09 320	1.13 330	1.16 341	1.20 352	1.29 377
32°F (0°C)	MMBTU kWh	1.03 300	1.06 310	1.09 320	1.13 331	1.21 356
50°F (10°C)	MMBTU kWh	0.99 290	1.02 299	1.05 309	1.09 319	1.17 344
68°F (20°C)	MMBTU kWh	0.95 279	0.98 288	1.02 298	1.05 308	1.13 332

## Specifications - 05-Series - WB-455 to WB-1805

Standard Specifications			WB-455	WB-555	WB-655	WB-755	WB-855	WB-1005	WB-1205	WB-1505	WB-1805
Nominal Vaporization Capacity <sup>1</sup>	gph		455	555	655	755	855	1005	1205	1505	1805
	kg/h		873	1065	1257	1449	1641	1929	2312	2888	3464
	MMBTU/h		42	51	60	69	79	92	111	139	166
	kcal/h x 10 <sup>6</sup>		11	13	15	18	20	23	28	35	42
Water Tank Capacity (to Fill Plug)	gal		220			385		495			990
	m <sup>3</sup>		0.83			1.46		1.87			3.75
Burner Capacity	MMBTU/h		0.54	0.66	0.78	0.9	1.02	1.2	1.44	1.8	2.16
	kW		158	193	229	264	299	352	422	528	633
Burner Type	Forced-Draft Power Burner, Maxon or similar; Low-Fire/High-Fire Modulation; DUNGS Main Gas Valve with PoC.										
Burner Configuration	4-inch TOT with integrated Blower					6-inch TOT with integrated Blower					8" TOT
Design Temperature	°F		650								
	°C		343								
Design Pressure	psi		250								
	bar		17.2								
Standard Safety Features			<p>Electronic Flame Safe Guard Honeywell 7800-Series; PLC Input with Status Indication at Operator Interface; Alarm History.</p> <p>Low Burner Fuel Gas Pressure All Burner Safety Interlocks, GasLeak Monitor contacts, and ESD circuits are connected to inputs at the agency-approved Safety Controller (Phoenix Contact PSR Tri-Safe). The Safety Controller energizes agency-approved expansion relays only if all safety circuits are "okay".</p> <p>High Burner Fuel Gas Pressure The expansion relays supply control power to the outputs of the PLC. If the Safety Controller detects a problem, the expansion relays are de-energized, effectively taking control power away from the outputs of the PLC.</p> <p>Low Water Level Cutoff This configuration makes the safety functions independent from the general-purpose PLC and elevates the safety classification of the vaporizer control system to Performance Level 4 (formerly known as SIL 3).</p> <p>High Bath Temperature Limit Safety Status is indicated at Operator Interface and recorded in Alarm History.</p> <p>GasLeak Monitor in Control Room 40% LEL "Smart"; Press. and Temp. transmitter in Vapor Outlet; selectable LPG Type; adjustable Safety Margin; Alarm History.</p> <p>GasLeak Monitor in Control Room Trouble</p> <p>Dual E-Stop Circuits</p> <p>Liquid Carryover Protection</p> <p>Relief Valve for Vaporization Tubes</p> <p>Relief Valve for Burner Gas Train</p>								
Liquid Inlet Connection	1" 300# Raised Face ANSI Flange (DN25 PN40 DIN Flange)						2" 300# RF ANSI (DN50 PN40 DIN Flange)				
Liquid Inlet Valve	250 psi Flanged Solenoid Valve; with Check Valve Bypass; Globe Valve for Manual Shutoff.										
Vapor Outlet Connection	2" 300# Raised Face ANSI Flange (DN50 PN40 DIN Flange)						3" 300# RF ANSI (DN80 PN40 DIN Flange)				
PLC and Electronic Operator Interface (EOI)			<p>Standard PLC / EOI Siemens S7-1200 PLC with Ethernet Interface; high-resolution Color LCD Touch Screen (800x480); Ethernet Interface; 96-hr Trend Recording; Trend Data for 2 years is saved on standard SD card and can be displayed in Microsoft Excel format; Remote Access to built-in VNC Server allows Monitoring and Control of all Vaporizer Functions; unlimited license for VNC Client Software is included and can be installed on multiple Laptops or PCs.</p> <p>Optional PLC / EOI Allen-Bradley MicroLogix-1100 PLC with Ethernet Interface; high-resolution Color LCD Touch Screen (800x480); Ethernet Interface; 96-hr Trend Recording; Trend Data for 2 years is saved on standard SD card and can be displayed in Microsoft Excel format; Remote Access to built-in VNC Server allows Monitoring and Control of all Vaporizer Functions; unlimited license for VNC Client Software is included and can be installed on multiple Laptops or PCs.</p> <p>Optional PLC / EOI Contact AES for other PLC/EOI configurations (Siemens, Allen-Bradley, GE, Bristol-Babcock, ...)</p>								
Electrical Requirements (other Voltages available)			380/400/480VAC 50/60Hz; 20A Circuit; 3-Phase; galvanically isolating transformer for control power included.								
Circuit Protection			Automatic Circuit Breakers with Manual Reset for all AC and DC Circuits; Main Breaker/Disconnect.								
Design Criteria			<p>Vaporizer Designed and manufactured to comply with the latest edition of NFPA Pamphlet 58; FM approved. European CE Mark available (third-party examination by TÜV Rheinland / TÜV Süd).</p> <p>LPG Heat Exchanger Designed and manufactured in compliance with Boiler and Pressure Vessel Code Section VIII, Division 1. ASME "U"-Stamp available. CE-marked vaporizers comply with European PED.</p> <p>Control Panel General-purpose wiring, compliant with National Electric Code (NEC; NFPA #70). UL-508A available. CE-marked vaporizers comply with all applicable European Directives.</p>								
Mechanical Construction			<p>Skid 1/4-inch (6.35mm) Steel Deck Plate on all-welded 6-inch (150mm) Channel Frame with Cross-Members; Lifting Lugs.</p> <p>Bath Box 1/4-inch (6.35mm) all-welded steel walls with internal stiffeners and supports for LPG Heat Exchanger.</p> <p>Water Circulating Pump Wet-Cartridge-Type Hot-Water Circulator installed inside Vaporizer Control Room. Diffuser in Water Bath.</p> <p>Insulation Mineral Fiber insulation with Aluminum backing on side walls, top plate, and rear wall.</p> <p>Bath Box Cover Siding: 16-gauge (1.5mm) Sheet Metal Panels, powder-coated gray (RAL 9002); Top-Cover: Aluminum Diamond Plate.</p> <p>Control Room 12-gauge (2.7mm) Sheet Metal, primed and painted blue (RAL 5015) or beige (RAL 1015); lockable door.</p>								
Dimensions <sup>2</sup>	( W x L x H )	inches	72 x 138 x 112			72 x 142 x 112		78 x 164 x 112			see
	( W x L x H )	m	1.83 x 3.51 x 2.84			1.83 x 3.61 x 2.84		1.98 x 4.17 x 2.84			WB-2005
Shipping Weight <sup>2</sup>		lbs (kg)	5400 (2500)			6200 (2900)		8000 (3700)			

(1) Nominal Capacity for Vaporization of HD-5 @ 0°F (-18°C) Liquid Temperature

(2) Dimensions and weights are approximate

Specifications subject to change without notice

## Specifications - 05-Series - WB-2005 to WB-10005

Standard Specifications		WB-2005	WB-2205	WB-2505	WB-3005	WB-3505	WB-4505	WB-5505	WB-7005	WB-10005	
Nominal Vaporization Capacity <sup>1</sup>	gph	2005	2205	2505	3005	3505	4505	5505	7005	10005	
	kg/h	3847	4231	4807	5766	6726	8645	10564	13442	19199	
	MMBTU/h	185	203	231	277	323	415	507	645	921	
	kcal/h x 10 <sup>6</sup>	46	51	58	70	81	104	128	162	232	
Water Tank Capacity (to Fill Plug)	gal	990			2035		2420		contact Factory		
	m <sup>3</sup>	3.75			7.71		9.16		contact Factory		
Burner Capacity	MMBTU/h	2.400	2.640	3.000	3.750	4.200	5.400	6.600	8.400	12.000	
	kW	703	774	879	1099	1231	1583	1934	2462	3517	
Burner Type	Forced-Draft Power Burner, Maxon or similar; Low-Fire/High-Fire Modulation; DUNGS Main Gas Valve with PoC.										
Burner Configuration	8-inch TOT with integrated Blower				8-inch TOT with external Blower				contact Factory		
Design Temperature	°F	650									
	°C	343									
Design Pressure	psi	250									
	bar	17.2									
Standard Safety Features		<p>Honeywell 7800-Series; PLC Input with Status Indication at Operator Interface; Alarm History.</p> <p>All Burner Safety Interlocks, GasLeak Monitor contacts, and ESD circuits are connected to inputs at the agency-approved Safety Controller (Phoenix Contact PSR Tri-Safe). The Safety Controller energizes agency-approved expansion relays only if all safety circuits are "okay".</p> <p>The expansion relays supply control power to the outputs of the PLC. If the Safety Controller detects a problem, the expansion relays are de-energized, effectively taking control power away from the outputs of the PLC.</p> <p>This configuration makes the safety functions independent from the general-purpose PLC and elevates the safety classification of the vaporizer control system to Performance Level 4 (formerly known as SIL 3).</p> <p>Safety Status is indicated at Operator Interface and recorded in Alarm History.</p> <p>"Smart"; Press. and Temp. transmitter in Vapor Outlet; selectable LPG Type; adjustable Safety Margin; Alarm History.</p>									
Electronic Flame Safe Guard											
Low Burner Fuel Gas Pressure											
High Burner Fuel Gas Pressure											
Low Water Level Cutoff											
High Bath Temperature Limit											
GasLeak Monitor in Control Room 40% LEL											
GasLeak Monitor in Control Room Trouble											
Dual E-Stop Circuits											
Liquid Carryover Protection											
Relief Valve for Vaporization Tubes		X	X	X	X	X	X	X	X	X	
Relief Valve for Burner Gas Train		X	X	X	X	X	X	X	X	X	
Liquid Inlet Connection		2" 300# Raised Face ANSI Flange (DN50 PN40 DIN Flange)							3" 300#RF (DN80 PN40)		
Liquid Inlet Valve		250 psi Flanged Solenoid Valve; Check Valve Bypass; Globe Valve for Manual Shutoff.									
Vapor Outlet Connection (Raised Face Flange)		3" 300# ANSI (DN80 PN40 DIN)			4" 300# ANSI (DN100 PN40 DIN)			6" 300# (DN150 PN40)			
PLC and Electronic Operator Interface (EOI)		<p>Siemens S7-1200 PLC with Ethernet Interface; high-resolution Color LCD Touch Screen (800x480); Ethernet Interface; 96-hr Trend Recording; Trend Data for 2 years is saved on standard SD card and can be displayed in Microsoft Excel format; Remote Access to built-in VNC Server allows Monitoring and Control of all Vaporizer Functions; unlimited license for VNC Client Software is included and can be installed on multiple Laptops or PCs.</p> <p>Allen-Bradley MicroLogix-1100 PLC with Ethernet Interface; high-resolution Color LCD Touch Screen (800x480); Ethernet Interface; 96-hr Trend Recording; Trend Data for 2 years is saved on standard SD card and can be displayed in Microsoft Excel format; Remote Access to built-in VNC Server allows Monitoring and Control of all Vaporizer Functions; unlimited license for VNC Client Software is included and can be installed on multiple Laptops or PCs.</p> <p>Contact AES for other PLC/EOI configurations (Siemens, Allen-Bradley, GE, Bristol-Babcock, ...)</p>									
Electrical Requirements (other Voltages available)		400/480VAC 50/60Hz; 25A Circuit; 3-Phase; galvanically isolating transformer for control power included.									
Circuit Protection		Automatic Circuit Breakers with Manual Reset for all AC and DC Circuits; Main Breaker/Disconnect.									
Design Criteria		<p>Vaporizer Designed and manufactured to comply with the latest edition of NFPA Pamphlet 58; FM approved. European CE Mark available (third-party examination by TÜV Rheinland / TÜV Süd).</p> <p>LPG Heat Exchanger Designed and manufactured in compliance with Boiler and Pressure Vessel Code Section VIII, Division 1. ASME "U"-Stamp available. CE-marked vaporizers comply with European PED.</p> <p>Control Panel General-purpose wiring, compliant with National Electric Code (NEC; NFPA #70). UL-508A available. CE-marked vaporizers comply with all applicable European Directives.</p>									
Mechanical Construction		<p>Skid 1/4-inch (6.35mm) Steel Deck Plate on all-welded 6-inch (150mm) Channel Frame with Cross-Members; Lifting Lugs.</p> <p>Bath Box 1/4-inch (6.35mm) all-welded steel walls with internal stiffeners and supports for LPG Heat Exchanger.</p> <p>Water Circulating Pump Wet-Cartridge-Type Hot-Water Circulator installed inside Vaporizer Control Room. Diffuser in Water Bath.</p> <p>Insulation Mineral Fiber insulation with Aluminum backing on side walls, top plate, and rear wall.</p> <p>Bath Box Cover Siding: 16-gauge (1.5mm) Sheet Metal Panels, powder-coated gray (RAL 9002); Top-Cover: Aluminum Diamond Plate.</p> <p>Control Room 12-gauge (2.7mm) Sheet Metal, primed and painted blue (RAL 5015) or beige (RAL 1015); lockable door.</p>									
Dimensions <sup>2</sup>	( W x L x H )	inches			84 x 204 x 112		80 x 240 x 112		80 x 310 x 112		80 x 460 x 138
	( W x L x H )	m			2.13 x 5.18 x 2.84		2.03 x 6.10 x 2.84		2.03 x 7.87 x 2.84		2.03 x 11.68 x 3.51
Shipping Weight <sup>2</sup>	lbs (kg)	14000 (6400)			16500 (7500)		20000 (9100)		38000(17300) 47000(21400)		

(1) Nominal Capacity for Vaporization of HD-5 @ 0°F (-18°C) Liquid Temperature

(2) Dimensions and weights are approximate

Specifications subject to change without notice

## Drawings, 05-Series

Full-Size Control Room:  
Standard on WB-455 to WB-1505.

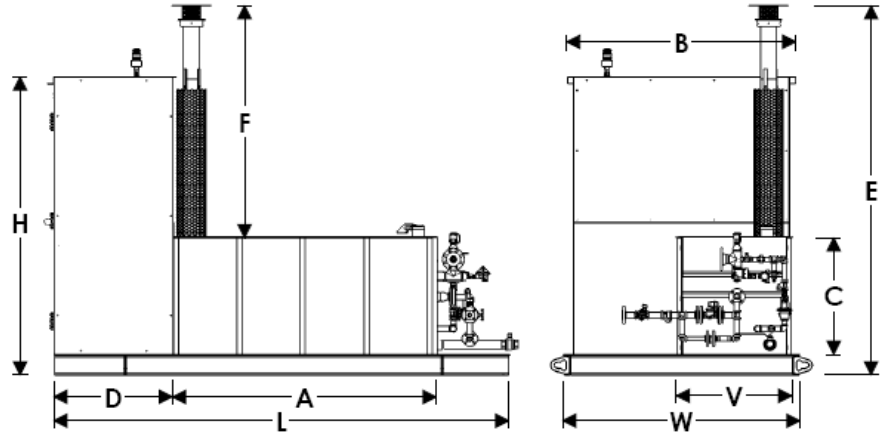

Extended Control Room:  
Standard on WB-1805 to  
WB-10005, optional for  
WB-455 to WB-1505.

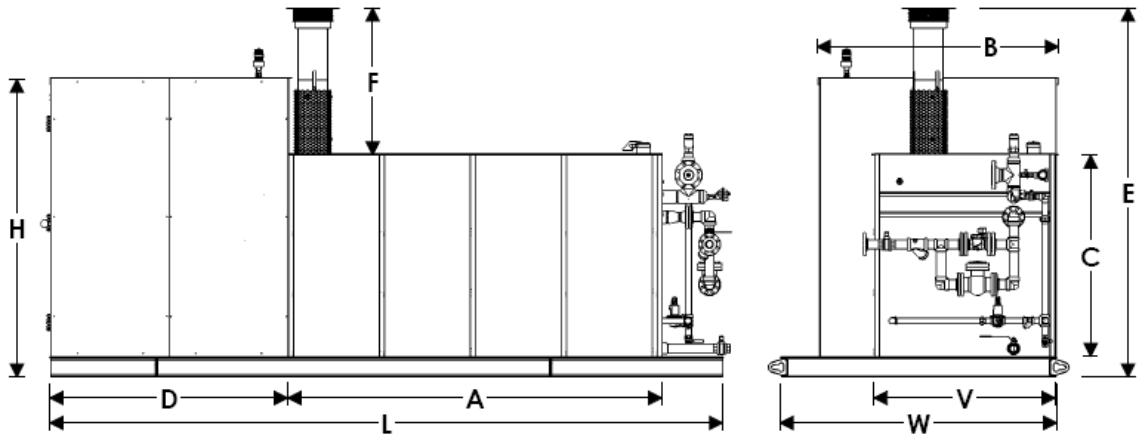

## Dimensions, 05-Series

### Dimensions for Vaporizers with Full-Size Control Rooms

(Dimensions are subject to change without notice)		W	L	H	V	A	B	C	D	E	F	Concrete Slab
WB-455, WB-555, WB-655	inches	72	138	91	35	80	66	36	36	112	70	8' x 15'
	m	1.83	3.51	2.30	0.89	2.03	1.68	0.91	0.91	2.85	1.78	2.50 x 4.20
WB-755, WB-855	inches	72	142	91	36	93	66	51	36	112	56	8' x 15'
	m	1.83	3.61	2.30	0.91	2.36	1.68	1.30	0.91	2.85	1.42	2.50 x 4.30
WB-1005, WB-1205, WB-1505	inches	78	164	91	40	105	66	54	36	112	52	8' x 17'
	m	1.98	4.17	2.30	1.02	2.67	1.68	1.37	0.91	2.85	1.32	2.50 x 4.90

### Dimensions for Vaporizers with Extended Control Rooms (Maintenance House)

(Dimensions are subject to change without notice)		W	L	H	V	A	B	C	D	E	F	Concrete Slab
WB-455, WB-555, WB-655	(Option) inches	72	174	91	35	80	66	36	72	112	70	8' x 17'
	m	1.83	4.42	2.30	0.89	2.03	1.68	0.91	1.83	2.85	1.78	2.50 x 5.00
WB-755, WB-855	(Option) inches	72	178	91	36	93	66	51	72	112	56	8' x 17'
	m	1.83	4.52	2.30	0.91	2.36	1.68	1.30	1.83	2.85	1.42	2.50 x 5.10
WB-1005, WB-1205, WB-1505	(Option) inches	78	200	91	40	105	66	54	72	112	52	8' x 19'
	m	1.98	5.08	2.30	1.02	2.67	1.68	1.37	1.83	2.85	1.32	2.50 x 5.70
WB-1805, WB-2005, WB-2205, WB-2505	inches	80	204	91	55	114	80	61	72	112	45	9' x 19'
	m	2.13	5.18	2.30	1.40	2.90	2.03	1.55	1.83	2.85	1.14	2.80 x 5.70
WB-3005, WB-3505	inches	80	240	91	78	142	80	65	84	112	41	9' x 19'
	m	2.13	6.10	2.30	1.98	3.61	2.03	1.65	2.13	2.85	1.04	2.80 x 5.70
WB-4505, WB-5505	inches	80	310	91	77	204	80	59	84	112	47	9' x 28'
	m	2.13	7.87	2.30	1.96	5.18	2.03	1.50	2.13	2.85	1.19	2.80 x 8.60
WB-7005, WB-10005	inches	80	460	113	79	289	80	80/100	148	138	28	9' x 41'
	m	2.13	11.68	2.87	2.01	7.34	2.13	2.13/2.54	3.76	3.51	0.71	2.80 x 12.50



## PLC Control Panels, First-Outage Monitor, Remote Access

All AES Water Bath Vaporizers are equipped with safety controls in accordance with NFPA 58, FM, and/or CE (see specifications on pages 4, 6, and 7). The safety controls are connected to an Agency-approved Safety Controller (EN ISO 13849-1) and are independent of the general-purpose PLC controls. This configuration elevates the safety classification of the vaporizer to "Performance Level 4" (formerly classified as SIL 3). Safety for the combustion system is provided by the electronic Honeywell Flame Safe Guard.

In addition to the connection to the Safety Controller, the vaporizer safety controls are also connected to the PLC, which provides status indication at the Electronic Operator Interface (EOI). All EOIs have a color LCD display with touch screen, and provide operator guidance through intuitive screen layouts and clearly labeled pushbuttons, indicators, numeric displays, etc. The EOIs also provide an Alarm History (First-Out Monitor), and graphic trend recording (96 hours). Alarm History and Trend Data are also recorded on a standard SD-card with a storage capacity of more than two years. Alarm History and Trend Data can be displayed on-screen, or can be retrieved for processing in Microsoft Excel format.

The standard PLC in all AES vaporizers is a Siemens S7-1200 with Ethernet communications interface. The standard EOI is a 7-inch high-resolution TouchPanel with 800x480 color LCD display.

The standard EOI has a built-in VNC server for remote access and monitoring via its Ethernet interface. An unlimited license of the VNC Client is included and can be installed on multiple Laptops or PCs.

Also available is an Allen-Bradley MicroLogix-1400 PLC (no additional charge), combined with the same type 7-inch high-resolution TouchPanel with 800x480 color LCD display.

Optional PLC/EOI combinations include:

- ⇒ Siemens S7-1200 with 8-inch (640x480) Siemens EOI with built-in Web Server.
- ⇒ Siemens S7-200 with 7-inch high-resolution (800x480) EOI.
- ⇒ Siemens S7-200 with 8-inch (640x480) Siemens EOI with built-in Web Server.
- ⇒ Allen-Bradley MicroLogix-1400 with 6-inch (320x240) Allen-Bradley PanelView-Plus EOI.
- ⇒ Allen-Bradley MicroLogix-1400 with 7-inch (640x480) Allen-Bradley PanelView-Plus EOI.
- ⇒ Other PLC/EOI brands (GE 90-30; Bristol ControlWave Micro; Siemens S7-300; Allen-Bradley SLC; Allen-Bradley CompactLogix; etc.) are available as options.

Please contact the factory if you require a specific configuration of the control system.

All AES Control Panels can be UL-508a stamped!  
All AES Control Panels are available with CE Mark!



Standard EOI for Siemens S7-1200, Siemens S7-200, or Allen-Bradley MicroLogix-1400:  
7-inch high-resolution (800x480) display with first-out monitor (Alarm History) 96-hour graphic TrendLine recording, trend data recording on standard SD card and remote access for monitoring and control via VNC Server / Ethernet. (unlimited client software license included).

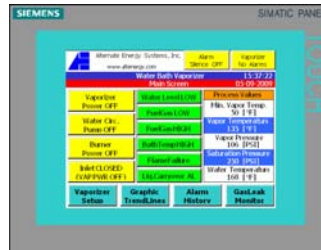

Optional EOI for Siemens PLC S7-1200 or S7-200:  
6-inch Siemens Touch Panel with built-in Web Server that allows Remote Monitoring (and Control) via a standard web browser without any special Software.

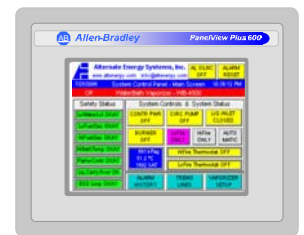

Optional EOI for Allen-Bradley PLC:  
6-inch PanelView-Plus display with first-out monitor (Alarm History) and graphic TrendLine recording. Applications developed for this EOI can also run on a PC with FactoryTalk View ME Station license (for remote monitoring).

## Control Room Sizes

All Water Bath Vaporizers have a compartment (vaporizer control room) in the front of the unit, holding burner, burner gas train, vaporizer control panel, temperature controls, water circulation pump, etc. The size of the vaporizer control room varies with the vaporizer size and the space required to accommodate the various sizes of burners and controls.

### 08-Series (WB-168 to WB-508)

The 08-Series vaporizers have a 48" x 48" (1.22m x 1.22m) Step-In Control Room with two wide-opening access door panels (40"; 1.02m). The access door has louvers for the combustion-air intake, a window-insert, and can be locked.

The control room in 08-Series vaporizers is equipped with light fixture, country-specific AC wall outlet, and GasLeak Monitor with long-life infrared sensor (expected sensor life 10+ years).

### 05-Series (WB-455 to WB-1505) Full-Size Control Room

The smaller 05-Series vaporizers have a 36-inch (0.91m) deep control room with 40-inch (1.02m) wide access door. The access door has louvers for the combustion-air intake, a window-insert, and can be locked.

The control room in 05-Series vaporizers is equipped with light fixture, country-specific AC wall outlet, and GasLeak Monitor with long-life infrared sensor (expected sensor life 10+ years).

WB-455 to WB-1505 vaporizers are also available with the optional Extended Control Room (see below).

### 05-Series (WB-1805 to WB-10005) Extended Control Room

The control room of 05-Series vaporizers WB-1805 and above has been extended to a depth of 72 inches (1.83m) to form a Walk-in Maintenance House. This provides additional weather protection for operating and maintenance personnel, and provides additional space for control components such as starters for the motors of liquid transfer pumps etc.

Extended Control Rooms are equipped with light fixture, country-specific AC wall outlet, and GasLeak Monitor with long-life infrared sensor (expected sensor life 10+ years).

In Vaporizer models WB-7005 and above, the combustion air blowers are installed in a separate compartment (noise reduction). This configuration is also available as an option for models WB-4505 and WB-5505.

**Extended Control Rooms are also available as an option for WB-455 to WB-1505 vaporizers.**

### Country-Specific Configuration

Vaporizers for export customers will be equipped with AC wall outlets and light fixtures that are common in their respective countries.

### Wall-Mounted Exhaust Fan, Heaters, Air Conditioning

All Control Rooms can be equipped with a thermostat-controlled fan to improve air circulation in warm climates. They can also be equipped with vinyl-backed insulation, and with electric heaters and/or air conditioning units.

## Specification-Summary, 08-Series, WB-168 to WB-508

	Nominal Vaporization Capacity				Burner Capacity		Water Tank Capacity		Dimensions in inches			Dimensions in m			Shipping Weight	
	gph	kg/h	MM BTU/h	kcal/h x 10 <sup>6</sup>	MM BTU/h	kW	gal	m <sup>3</sup>	W	L	H	W	L	H	lbs	kg
WB- 168	168	322	15.5	3.9	0.200	59	165	0.625	48	132	110	1.22	3.35	2.79	3500	1600
WB- 208	208	399	19.1	4.8	0.250	73	165	0.625	48	132	110	1.22	3.35	2.79	3500	1600
WB- 258	258	495	23.7	6.0	0.310	91	165	0.625	48	132	110	1.22	3.35	2.79	3500	1600
WB- 308	305	585	28.1	7.1	0.370	108	165	0.625	48	132	110	1.22	3.35	2.79	3500	1600
WB- 358	358	687	32.9	8.3	0.430	126	165	0.625	48	132	110	1.22	3.35	2.79	3700	1700
WB- 408	408	783	37.5	9.5	0.490	144	165	0.625	48	132	110	1.22	3.35	2.79	3700	1700
WB- 458	458	879	42.5	10.6	0.550	161	165	0.625	48	132	110	1.22	3.35	2.79	3700	1700
WB- 508	508	975	46.8	11.8	0.610	179	165	0.625	48	132	110	1.22	3.35	2.79	3700	1700

Specifications are subject to change without notice

## Specification-Summary, 05-Series, WB-455 to WB-10005

	Nominal Vaporization Capacity				Burner Capacity		Water Tank Capacity		Dimensions in inches			Dimensions in m			Shipping Weight	
	gph	kg/h	MM BTU/h	kcal/h x 10 <sup>6</sup>	MM BTU/h	kW	gal	m <sup>3</sup>	W	L	H	W	L	H	lbs	kg
WB- 455	455	873	42	11	0.54	158	220	0.830	72	138	112	1.83	3.51	2.84	5400	2500
WB- 555	555	1065	51	13	0.66	193	220	0.830	72	138	112	1.83	3.51	2.84	5400	2500
WB- 655	655	1257	60	15	0.78	229	220	0.830	72	138	112	1.83	3.51	2.84	5400	2500
WB- 755	755	1449	69	18	0.90	264	385	1.460	72	142	112	1.83	3.61	2.84	6200	2900
WB- 855	855	1640	79	20	1.02	299	385	1.460	72	142	112	1.83	3.61	2.84	6200	2900
WB- 1005	1005	1928	92	23	1.20	352	495	1.870	78	164	112	1.98	4.17	2.84	8000	3700
WB- 1205	1205	2312	111	28	1.44	422	495	1.870	78	164	112	1.98	4.17	2.84	8000	3700
WB- 1505	1505	2888	139	35	1.80	528	495	1.870	78	164	112	1.98	4.17	2.84	8000	3700
WB- 1805	1805	3463	166	42	2.16	633	990	3.750	84	204	112	2.13	5.18	2.84	14000	6400
WB- 2005	2005	3847	185	46	2.40	703	990	3.750	84	204	112	2.13	5.18	2.84	14000	6400
WB- 2205	2205	4231	203	51	2.64	774	990	3.750	84	204	112	2.13	5.18	2.84	14000	6400
WB- 2505	2505	4807	231	58	3.00	879	990	3.750	84	204	112	2.13	5.18	2.84	14000	6400
WB- 3005	3005	5766	277	70	3.75	1099	2035	7.710	80	240	112	2.03	6.10	2.84	16500	7500
WB- 3505	3505	6726	323	81	4.20	1231	2035	7.710	80	240	112	2.03	6.10	2.84	16500	7500
WB- 4505	4505	8645	415	104	5.40	1583	2420	9.160	80	310	112	2.03	7.87	2.84	20000	9100
WB- 5505	5505	10534	507	128	6.60	1934	2420	9.160	80	310	112	2.03	7.87	2.84	20000	9100
WB- 7005	7005	13442	645	162	8.40	2462	6200	23.5	80	460	138	2.03	11.68	3.51	38000	17300
WB-10005	10005	19199	921	232	12.0	3517	8600	32.6	80	460	138	2.03	11.68	3.51	47000	21400

Specifications are given for standard configurations and are subject to change without notice.

### Request Quotation

To Request a Quotation for a vaporizer, use the format below to provide us with basic information about your application. The specifications shown in this brochure and the options shown on the opposite page are only a small selection of all available options — you can substitute (almost) everything with your own preference.

If you are unclear how to specify the system, or if you have any additional questions, please contact us by email at [sales@altenergy.com](mailto:sales@altenergy.com), or by phone at +1 770 487 8596. Once we receive your RFQ, we will respond within one business day with a price and an available manufacturing slot, and within two business days with estimated shipping costs to your location.

#### EXAMPLE

WB-655	1200	kg/h	30Prop/70But	415V 50Hz	Ext.Contr.Room	A-B PLC	7-inch EOI	ASME U-Stamp	see Notes
Model Number <sup>1</sup>	Capacity <sup>2</sup>	Units <sup>3</sup>	LPG Type <sup>4</sup>	Electricity <sup>5</sup>	Option <sup>6</sup>	Option <sup>6</sup>	Option <sup>6</sup>	Option <sup>6</sup>	Option <sup>7</sup>

1 Select from list above, or leave blank, if you want AES to recommend model

2 Enter your connected load or your observed momentary LPG consumption

3 Enter Engineering Units

4 Enter HD-5 or actual LPG composition (Propane / Butane percentage)

5 Enter available electricity

6 Enter Option(s) from list on opposite page

7 Include additional notes to describe your particular application or non-standard configuration requirements.

This could include different inlet/outlet connections; software for remote communications; different paint colors; special shipping instructions; etc.

## Standard Options and Standard Accessories, WB-168 to WB-10005

Option	Description	
ASME U-Stamp	LPG Heat Exchanger with ASME U-Stamp and Registration with the National Board of Boiler and Pressure Vessel Inspectors. Option includes UL-Stamped Relief Valve for LPG heat Exchanger.	
	WB-168 WB-208 WB-258 WB-308 WB-358 WB-408 WB-458 WB-508	optional
	WB-458 WB-508 WB-455 WB-555 WB-655 WB-755 WB-855	optional
	WB-1005 WB-1205 WB-1505 WB-1805 WB-2005 WB-2205	optional
	WB-2505 WB-3005 WB-3505 WB-4505 WB-5505	optional
	WB-7005 WB-10005	standard
Extended Control Room	Extended Control Room with Light Fixture and country-specific AC Wall Outlet	
	WB-458 WB-508 WB-455 WB-555 WB-655 WB-755 WB-855 WB-1005 WB-1205 WB-1505	optional
	WB-1805 WB-2005 WB-2205 WB-2505 WB-3005 WB-3505 WB-4505 WB-5505 WB-7005 WB-10005	standard
	Exhaust Fan - Electric Heater - Air Conditioner	optional
Control Panel 508a	UL-508a Stamp for Vaporizer Control Panel	
	WB-168 WB-208 WB-258 WB-308 WB-358 WB-408 WB-458 WB-508	optional
	WB-458 WB-508 WB-455 WB-555 WB-655 WB-755 WB-855 WB-1005 WB-1205 WB-1505	optional
	WB-1805 WB-2005 WB-2205 WB-2505 WB-3005 WB-3505 WB-4505 WB-5505	optional
	WB-7005 WB-10005	optional
PLC + EOI	Siemens S7-1200 with Profinet (Ethernet) and 7-inch high-resolution (800x480) Touch Panel	standard
	Allen-Bradley MicroLogix-1400 with 7-inch high-resolution (800x480) Touch Panel	no addtl. charge
	Siemens S7-1200 with 6-inch (320x240) Siemens Touch Panel with built-in Web Server for Remote Access and Control	optional
	Siemens S7-1200 with 8-inch (640x480) Siemens Touch Panel with built-in Web Server for Remote Access and Control	optional
	Siemens S7-1200 with Profinet and Profibus DP Interface and 7-inch high-resolution EOI (800x480)	optional
	Allen-Bradley MicroLogix-1400 with 6-inch Allen-Bradley PanelView-Plus (320x240)	optional
	Allen-Bradley MicroLogix-1400 with 7-inch Allen-Bradley PanelView-Plus (640x480)	optional
	Allen-Bradley Factory Talk View ME Station; Software with single license for remote access to PanelView-Plus panels	optional
	GE 90-30; Bristol ControlWave Micro; Siemens S7-300; Allen-Bradley SLC; Allen-Bradley CompactLogix; etc.	optional

## ProCool™-50 Heat Transfer Solution

Water Bath Vaporizers use - as the name implies - water as the heat transfer medium. However, since the heat exchanger components and the bath box of the WB series are manufactured from carbon steel, it is recommended that the heat transfer solution be a mixture of water and an industrial coolant/heat transfer fluid with inhibitors to provide rust/corrosion protection.

Under no circumstances should an automotive grade coolant be used as the heat transfer fluid. Using standard automotive coolant could cause premature deterioration of the heat exchangers.

It is also recommended that the water in the heat transfer solutions be de-ionized. While it is acceptable to use small amounts of standard tap-water to replenish any water that might have evaporated, it is not recommended to use standard tap-water for the initial charge of the water bath. If at all possible, topping-off should be done with pre-diluted solutions of corrosion-inhibited heat transfer solution at the required system concentration.

Alternate Energy Systems recommends a 50/50 Propylene-Glycol/DI-Water solution for all installations. This mixture will provide burst protection to -60°F (-50°C), and will provide freeze protection to -30°F (-34°C), while providing a maximum of corrosion protection.

In cooperation with a leading manufacturer of corrosion-inhibited Propylene-Glycol, Alternate Energy Systems offers ProCool™ heat transfer fluid for all WB-series Water Bath Vaporizers. We are stocking ProCool™-100 heat transfer fluid (undiluted), and ProCool™-50 (pre-mixed 50/50 with DI-Water), in 55-gallon drums and in 275-gallon totes, and can ship the quantities needed for the initial charge on the same truck as the vaporizer at no, or very minimal, additional shipping charges. If required, we can also provide a small utility pump, complete with suction hose and discharge hose, for the transfer of the ProCool™ heat transfer fluid from the drums or totes to the vaporizer.

AES Part #	Description	
HTS1055	ProCool™-50 heat transfer solution in 55-gallon non-returnable plastic drum (see Note 2)	available
HTS1275	ProCool™-50 heat transfer solution in 275-gallon non-returnable plastic tote with steel-cage reinforcement (see Note 2)	available
HTS0004	Maintenance Sample Kit, including self-addressed shipping box, pre-labeled sample bottle, weather-proof self-adhesive product installation tag and detailed sampling procedures. Analytical results from the samples will be forwarded by the laboratory directly to our customer.	See Note 1
HTS0005	Utility Pump Kit for the transfer of ProCool™-50 from the shipping containers to the vaporizer. Kit includes industrial-grade pump for AC110V 60Hz Single Phase (transfer rate approximately 365 gallons per hour); 10-ft. suction hose; 40-ft. discharge hose.	available

Note 1: Available at no charge to customers who have purchased their Heat Transfer Solution through AES. Contact AES for pricing if your Heat Transfer Solution is not ProCool™-50, or if it was not purchased from AES.

Note 2: ProCool™-50 is delivered in non-returnable containers. The cost of the containers is included in the price of the Heat Transfer Solution. AES accepts returned containers (freight pre-paid) for recycling and will credit the customer's account \$10.00 for each returned 55-gallon drum, and \$20.00 for each returned 275-gallon tote.

# Who is Alternate Energy Systems, Inc. ?

After working for other manufacturers of LPG vaporizers and LPG / air systems for several years, John E. Hallberg founded Alternate Energy Systems, Inc. in 1974 in Peachtree City, located just 20 minutes south-west of the Atlanta airport. He successfully set out to design and manufacture products which were superior to those of his competitors. As a result, AES became very quickly known as the innovative manufacturer of quality products. Soon, the customer list included a representative cross-section of the Fortune 500 companies in the U.S.



Through the years, AES has constantly added new products, and has further improved the design of existing products, keeping us ahead of the competition. Several designs, including those for LPG/Air mixing systems, were awarded national and international patents.

Today, AES is owned by Wolfgang Driftmeier. With his manufacturing background and his experience in sales and marketing, the company focus is clearly on "... offering the best product design, combined with quality workmanship, at a competitive price, to the full satisfaction of our customers, at all times ...".

AES is committed to serving customers in the U.S. through a network of sales specialists, technical support personnel, distributors and installers, and international customers in selected countries through qualified representatives.

Please visit our web site at [www.altenergy.com](http://www.altenergy.com) for updated versions of all data sheets, price lists, application notes, a list of authorized distributors, and other documents that are only available online.

## Other Products from Alternate Energy Systems, Inc.

Water Bath Vaporizers  
Hot Water Vaporizers  
Steam Vaporizers

Venturi Type LPG / Air Mixers  
Patented Piston Operated LPG / Air Mixers

Complete Vaporizer / Mixer Systems  
Peak Shaving Plants  
Gas Stabilization Systems

Accessories for LPG / Air Systems  
LPG Pump Packages

Service  
Maintenance  
Trouble Shooting

## Our Address

Alternate Energy Systems, Inc.  
210 Prospect Park P.O. Box 2469  
Peachtree City, GA 30269, USA

Phone 770-487-8596  
Fax 770-631-4306  
Toll Free 800-410-9161

E-Mail [info@altenergy.com](mailto:info@altenergy.com)  
WebSite [www.altenergy.com](http://www.altenergy.com)

## Your AES Distributor