



# Alternate Energy Systems, Inc.

A Corporation devoted to Energy Oriented Needs

## Installation, Operating and Instruction Manual Direct Fired LPG Vaporizers (Rev. Sep. 2004)



Models with Single Heat Exchanger  
REGO Regulator and Relief Valve:

AE – 50R  
AE – 80R  
AE – 120R

Models with Multiple Heat Exchangers  
REGO Regulator and Relief Valve:

DF – 1600R  
DF – 2400R  
DF – 3600R  
DF – 4800R



Models with Single Heat Exchanger  
FISHER Regulator and Relief Valve:

AE – 50F  
AE – 80F  
AE – 120F

Models with Multiple Heat Exchangers  
FISHER Regulator and Relief Valve:

DF – 1600F  
DF – 2400F  
DF – 3600F  
DF – 4800F

**Note:**

The photos and illustrations in this booklet show mainly the R-model vaporizers (with REGO regulator); explanations and instructions are identical for vaporizer models with FISHER regulators.

**Disclaimer:**

All information provided in this manual has been developed over many years of direct involvement in the LPG industry and is believed to be accurate. However, no claim is made that this booklet covers all rules and regulations of all authorities having jurisdiction over all installation locations worldwide.

Alternate Energy Systems, Inc. strongly recommends that the installer and/or operator of the equipment covered by this manual consult the latest versions of NFPA 58 and any local rules (such as the State Boiler and Pressure Vessel Codes), and any additional, specific requirements for a given location, prior to installation.

Canadian customers will also have to comply with rules and regulations issued by Canadian Provincial and local authorities, TSSA requirements, and other applicable rules. As a minimum, CSA B149, Installation Code for Gas Burning Appliances and Equipment, should be consulted.

Alternate Energy Systems, Inc. strives to continually improve our products. As a result, specifications, including materials and components used, are subject to change without notice.

**Limited Warranty:**

Alternate Energy Systems, Inc. (AES) guarantees that all vaporizers covered by this manual shall be free of defects in workmanship and material for a period of one year from date of shipment. Defects caused by normal wear or tear, are explicitly excluded. Commercial items, and other components, such as controls, electric motors, drives, etc., utilized in these products, are not guaranteed by AES and are subject to their respective manufacturers' guarantee only. Complete products represented by, distributed by, or purchased and resold in any other manner by AES, are not guaranteed by AES, but will be subject to applicable manufacturer's guarantee. In the event of defects occurring during the covered warranty period as a result of normal and proper use, AES will only be obligated to furnish, f.o.b. AES plant, without charge, parts required to replace defective materials; or at our option, replacement of defective item. AES and our suppliers shall not be held liable for any further costs or expense, or for indirect or consequential damages, including removal or reinstallation, lost profits, etc. Deterioration or wear caused by chemicals, abrasive action, or excessive heat, shall not constitute defects under warranty, unless such conditions are specifically provided for by AES in writing. Products or parts that have been subject to accidental damage, misuse by the user, unauthorized disassembly or alterations, improper installation, or lack of proper lubrication or other service requirements established by the manufacturer, will not be covered by this warranty. THE WARRANTY STATED HEREIN IS IN LIEU OF ALL OTHER WARRANTIES, EXPRESS, STATUTORY OR IMPLIED, INCLUDING, WITHOUT LIMITATION, THAT OF MERCHANTABILITY AND FITNESS FOR A PARTICULAR PURPOSE.

## Table of Contents

<b>I. Introduction</b> .....	<b>5</b>
Where Should You Begin Reading? .....	5
What is in this Manual? .....	5
What You Should Know About Alternate Energy Systems, Inc. (AES) .....	6
<b>II. Quick Start</b> .....	<b>7</b>
Installation .....	7
Start-Up .....	7
<b>III. LP Gas, Precautions, and Summary of NFPA Requirements</b> .....	<b>8</b>
LP Gas, LPG .....	8
Precautions .....	8
Summary of NFPA Requirements .....	9
NFPA 58 and Local Requirements for ASME Stamps .....	10
<b>IV. Pre-Installation Inspection</b> .....	<b>10</b>
<b>V. Your Vaporizer</b> .....	<b>11</b>
Function of the Direct Fired Vaporizer .....	11
Features of the Direct Fired Vaporizer .....	11
Components of the Direct Fired Vaporizer .....	12
Cutaway drawing of the Direct Fired Vaporizer .....	13
<b>VI. Installation</b> .....	<b>14</b>
Unpack and Anchor Unit .....	14
Install the Outlet Piping .....	14
Install the Inlet Piping .....	16
Typical Installation Configuration .....	16
Test the System for Gas Leaks .....	17
Test the System for Correct LPG Gas Pressure .....	18
Ignite the Gas Burner .....	18
Typical Installation Configuration .....	20
<b>VII. Vaporizer Start-Up and Shut-Down</b> .....	<b>21</b>
Starting the Direct Fired Vaporizer .....	21
Control Settings for On-Going Operation .....	23
Control Settings for Long Periods of Shut-Down .....	23
Complete Shut-Down .....	23
<b>VIII. Maintenance</b> .....	<b>24</b>
Periodic Maintenance Procedures .....	24
Weekly .....	24
Monthly .....	24
Annually .....	24
Procedure for Washing Heavy Ends .....	24
Procedure for Removal of Heavy Ends from Burner Regulator Drip Leg .....	25
Gas Control Valve Maintenance .....	26
Notes for Gas Control Valve Replacement .....	26

(Continued on next page.)

---

<b>IX. DF-Series</b> .....	<b>27</b>
DF-Series Components .....	27
DF-Series Procedures .....	27
<b>Appendix A - Telephone and Internet Assistance</b> .....	<b>28</b>
<b>Appendix B - Trouble Shooting</b> .....	<b>28</b>
<b>Appendix C - Spare Parts</b> .....	<b>30</b>
<b>Appendix D - Glossary of Terms</b> .....	<b>31</b>
<b>Appendix E - Electric Re-Igniters</b> .....	<b>33</b>
9V Battery Operated Igniter .....	33
AC 110V 50/60 Hz Igniter .....	33
<b>Appendix F - Approvals</b> .....	<b>34</b>
FM Approval (Factory Mutual).....	34
CSA Approval (Canadian Standards Association) .....	34
CGA Approval (Canadian Gas Association) .....	34
<b>Appendix G - Installation of Multiple Vaporizers in One Location</b> .....	<b>35</b>

## I. Introduction

This chapter describes how the manual is organized, including brief descriptions about the content of each chapter. It also provides you with some basic information about our company.

### Where Should You Begin Reading ?

If you have installed an Alternate Energy Systems vaporizer recently, you may want to turn directly to Chapter II, "Quick Start", just to review the installation and starting procedure. However, if you haven't installed one of our vaporizers before - or, if you simply want more information - continue reading.

### What Is In This Manual ?

This manual contains installation instructions and other important information about your Direct Fired Vaporizer.

**Chapter One** includes this description about the structure of this manual and it's organization. It also provides some information about our company.

**Chapter Two** is a highly summarized list of installation steps, and is intended as a "refresher" or checklist for an experienced installer only.

**Chapter Three** discusses certain LP Gas properties, which you should know about; lists certain precautions you should take; and summarizes NFPA 58 requirements, which may be applicable to your installation.

**Chapter Four** outlines the pre-installation inspection steps you should take before installing the vaporizer.

**Chapter Five** provides a detailed description of the Direct Fired Vaporizer.

**Chapter Six** presents a step-by-step installation procedure. This chapter provides more detail than the brief description provided in Chapter Two.

**Chapter Seven** describes the starting procedure for the vaporizer, control settings for on-going operation, and how to prepare the vaporizer for long shut-down periods.

**Chapter Eight** includes procedures for periodic and as-needed maintenance.

**Chapter Nine** provides a description of the DF series Direct Fired Vaporizers.

**The Appendices** include information about obtaining telephone assistance, trouble shooting procedures, a list of recommended spare parts, a glossary of terms, available electric re-igniter, a copy of the product data sheet, and excerpts from approval listings of FM (Factory Mutual), CSA (Canadian Standards Association), and CGA (Canadian Gas Association).

## What You Should Know About Alternate Energy Systems, Inc. (AES)

AES began manufacturing operations in 1974 and is now recognized as the LPG equipment industry leader. In addition to manufacturing LPG vaporizers and related equipment, we have the resources and experience to assist you with all other LPG fuel related questions.

We believe you should know that you've purchased more than just an outstanding product. Your AES Direct Fired Vaporizer carries with it an entire corporate philosophy targeted at the objectives:

“ ... offering the best product design, combined with quality workmanship, at a competitive price, to the full satisfaction of our customers, at all times, while maintaining our industry leadership in design, engineering, construction and safety ...”.

In addition to the Direct Fired Vaporizer, we have also developed, and are manufacturing, the following products:

- Water Bath Vaporizers
- Steam Vaporizers
- Circulating Hot Water Vaporizers
- Gas/Air Blending Systems
- Truck Unloading Stations
- Liquid Transfer Pump Packages
- Flare Burner Assemblies
- Oil Separators

You will see evidence of our commitment to engineering quality products in the vaporizer you've just purchased. For example, our design includes a temperature control valve (thermostat) with a remote temperature probe and a stainless steel thermowell. The thermowell is designed to maintaining the integrity of the heat exchanger, even if the temperature control valve should fail. This is a feature not offered by any other product on the market today.

We have also incorporated other design characteristics, such as the welding of heat transfer fins to the vaporizer tube that provides more effective and efficient heat dissipation, and using a single tube to control the liquid level and temperature. Externally, our units are constructed with a thicker sheet metal than that found in competitive units. For a more detailed description of the vaporizer features, please read Chapter V.

We are proud of our company and our commitment to quality, customer satisfaction, engineering superiority, and safety.



## II. Quick Start

This chapter provides summary-level installation instruction only, and is intended for the experienced AES Direct Fired Vaporizer installer only. If you have not specifically installed an Alternate Energy Systems "AE" or "DF" series unit, turn to Chapter VI. Otherwise, use the following checklist to guide your installation.

### Installation

- Connect safety relief valve to unit
- Affix unit to level concrete platform
- Install 3000# pipe union to outlet pipe
- Use approved pipe sealing compound
- Install shutoff valve
- Install pressure regulator
- Install pressure relief valve
- Connect to outlet-side device
- Install 3000# pipe union to inlet pipe
- Install 400 W.O.G., 80 mesh "Y" strainer
- Install 400 W.O.G. shutoff valve
- Connect to fuel source
- Close outlet valve
- Open inlet valve
- Place soap solution on all joints, fittings, etc.
- Check for leaks
- Open burner valve

### Start-Up

- Light the pilot
- Check burner and pilot lines for leaks
- Move temperature selector (green knob) counter-clockwise to the HI position
- After burner shuts off, open outlet valve
- Adjust pressure at outlet regulator
- Set outlet pressure relief valve to 125%-250% of regulator setting

### III. LP Gas, Precautions, and Summary of NFPA Requirements

This chapter provides general information about LP Gas, discusses certain precautions you should take, and presents a summary of The National Fire Protection Association requirements regarding Direct Fired Vaporizer installation.

#### LP Gas, LPG

Propane, propylene, butane, and butylene, all fall under the general term "LPGas". Under pressure, each becomes a liquid. At atmospheric pressure, at "normal" ambient temperatures, each is a gas.

LP Gas is typically stored and distributed in its liquid state in pressurized containers. When LP Gas is released from the pressurized container, it quickly changes from a liquid to a gas. However, even in its gaseous state, always remember that it is heavier than air. If the gas is released in small quantities, it will generally mix with the air and harmlessly scatter. Released in greater quantities, the gas may spread over an area in flammable concentrations. You must be careful because a spark or other ignition source can cause a fire or explosion in either case.

LP Gas is highly flammable and can be extremely dangerous if not handled properly. Although colorless and odorless, an additive is usually combined with the gas to give it an odor so that leakage can be detected. LP Gas is also non-toxic; however, large concentrations can cause oxygen deficiency. As a result, inhalation can result in asphyxiation.

The mixture of LP Gas and air make a potentially explosive combination. A mixture of LP Gas and air is explosive when as little as 2.15% and not more than 10% of the mixture is LP Gas. When LP Gas changes from a liquid to a gas, it expands its volume by approximately 272 times.

#### Precautions

You should observe the following general precautions whenever you are working with LP Gas:

- DO NOT SMOKE when you are near storage tanks, transport trucks, or other related equipment.
- Keep all other vehicles, gasoline engines, and electrical motors away from the storage tanks, transport trucks, and related equipment. A running engine or motor can provide the spark needed to cause a fire or explosion.
- DO NOT remove plugs or caps on connections if shut off valves leak.
- Make sure all unloading connections are tight.
- Make sure you understand the purpose and operation of all valves and other equipment before using.
- DO NOT tamper with relief valves.
- Open any valve SLOWLY.
- NEVER place your face, head, hands, or any other part of your body over safety relief valves.
- DO NOT overfill LP Gas storage containers.
- DO NOT allow LP Gas to touch your skin or clothing. The gas evaporates very quickly and can cause freezing.



---

## Summary of NFPA Requirements

As previously discussed, all AES Direct Fired Vaporizers are engineered and manufactured under strict quality control, and meet all ASME and NFPA publication 58 requirements. In order to create a safe environment for the installation and operation of your unit, you must also understand the requirements related to installation. We urge you to obtain a copy of NFPA publication 58, and read the appropriate sections regarding installation. The following paragraphs are a summarization only, and are not intended to take the place of the NFPA document.

Direct fired vaporizers may be installed either outdoors, or inside a building. The following information pertains to the building that houses the vaporizer.

- The building shall be one story tall.
- The walls, floors, ceilings, and roofs shall be constructed of non-combustible materials.
- If the building's exterior walls, ceilings, and roofs are constructed of lightweight material, they must be designed for explosion venting.
- The building's floor cannot be constructed below ground level.
- The building must have either natural or mechanical ventilation.
- If the building's exterior walls, ceilings, and roofs are constructed of heavy material (e.g. reinforced concrete, concrete block, etc.), the building must have explosion venting windows or panels which provide a venting area of at least 1 sqft for each 50 cuft of enclosed volume.
- If the building uses natural ventilation, there must be at least one opening for every 20 ft in length of exterior wall. Each opening must be at least 50 sqin. The total of all openings must have at least 1 sqin of opening for every 1 sqft of flow area.
- If the building uses mechanical ventilation, the rate of air circulation must be at least 1 cuft per minute for every 1 sqft of floor area. Ventilation outlets must be at least 5 ft. away from any openings.
- If the building is heated by steam, hot water, or other similar medium, the heat source must be outside the building.
- If the building is heated by an electrical appliance, it must be listed for installation in Class I, Group D, Division 2 locations (NFPA 70, National Electrical Code, Table 3-8.2.2).
- The building which houses the Direct Fired Vaporizer may not be used for any other purpose (i.e. no other equipment installed or any other use) unless that purpose is gas manufacturing or distributing. The building must also comply with the requirements previously described. Additionally, the building may not have any openings in the wall separating the vaporizer from other LP Gas vaporizers, pumps, or central gas mixing devices.
- The building may not have an unprotected drain or sump pit.
- Direct fired vaporizers housed inside buildings must have pressure relief valves piped outside the building and must point upward.

---

## Summary of NFPA Requirements (continued)

The following information pertains to installations either within a building, or outside:

- A manually operated shut-off valve must be in place at each fuel container connection to stop the complete flow of all vapor or liquid.
- Minimum distances from the vaporizer to:

Container	10 ft. (3m)
Container Shutoff Valves	15 ft. (5m)
Point of Transfer	15 ft. (5m)
Other buildings / property line	25 ft. (8m)
Building housing gas-air mixer	10 ft. (3m)

## NFPA 58 and Local Requirements for ASME Stamps

NFPA 58 requires all fired pressure vessels to be inspected by an authorized ASME inspector, and to carry the ASME “S” stamp.

Alternate Energy Systems, Inc. is authorized to carry the ASME “S”, “U” and “R” stamps and is authorized to register pressure vessels with The National Board of Boiler and Pressure Vessel Inspectors (Nat’l Board).

Where required, all AE/DF direct fired vaporizers carry the “S” stamp on the data plate on the outside of the heat exchanger, and on a duplicate data plate that is permanently welded to the top of the heat exchanger, inside the heat exchanger insulation.

## IV. Pre-Installation Inspection

Before beginning installation, a thorough inspection of the installation site and all equipment should be completed to ensure that all equipment, valves, fittings, connectors, and lines are prepared and safe.

The following general steps should be taken during the inspection:

- Conduct both a visual and physical (using soap solution or gas detector) inspection for leaks on and around any storage tanks, pumps, unload stations, vaporizers, mixers, and the like.
- Open all valves in line with pressure measuring devices.
- Observe and record any available temperature, pressure, level, or other gauge readings.
- Check status of all other valves.
- Inspect all connections to ensure any necessary protective caps/plugs are in place.

## V. Your Vaporizer

This chapter describes the function, features, and specific components of your Direct Fired Vaporizer.

### Function of the Direct Fired Vaporizer

The function of all models of the Direct Fired Vaporizer is to safely and efficiently take liquid LPG from a container, heat it until it reaches a gaseous state, and then send it along fuel output lines to its destination.

### Features of the Direct Fired Vaporizer

All models of the Direct Fired Vaporizer are designed to operate in any climate, provide years of service, and require minimum maintenance.

The vaporizer model numbers are AE-50, AE-80, AE-120, DF-1600, DF-2400, DF-3600, and DF-4800. The model number (for DF-series: the first 3 digits of the model number) indicate the gallons per hour propane vaporization capacity at 0°F inlet temperature for each unit. There may also be one or more suffixes to the model number, indicating a particular vaporizer configuration (R=REGO regulator and relief valve; F=FISHER regulator and relief valve; GR or GF=configuration for extreme cold climates).

All vaporizers are designed and manufactured under the strict quality control procedures set forth by both the American Society of Mechanical Engineers (ASME) Code and the National Fire Protection Association (NFPA) publication number 58: *Standard for the Storage and Handling of Liquefied Petroleum Gases*.

In accordance with these strict procedures, the units are approved for Factory Mutual (FM) and Canadian Standards Association (CSA) installations, and are suitable for Industrial Risk Insurers (IRI) installations. The units do not require any electrical source for operation.

The following features are standard on all units:

- LPG level is controlled by a unique, precision valve. This valve is positioned outside the cabinet and is away from the high temperatures.
- The brass liquid inlet valve resists pitting and corrosion, and is simple to remove for cleaning.
- Stainless steel ball float with a 500 PSI pressure rating.
- Dual liquid level control to prevent liquid carryover.
- 250# safety relief valve.
- Finned vaporizer tube for optimum heat exchange.
- Outside air louvers engineered to minimize clogging with snow, or cause drafts that may extinguish the pilot light.
- Pilot light outage protected by thermocouple.
- Multi-orifice burner and a steel vent cap which, together, promote quick ignition and complete combustion.
- Corrosion resistant burner shroud.

- 3000° F refractory fiber insulation to minimize heat loss.
- Easy access and inspection via removable front door panel.
- Ample drip leg to prevent heavy ends from fouling the temperature control valve.
- A two-stage burner regulator to provide a stable, consistent pressure.
- Integrated drain vent for the removal of accumulations (heavy ends) from the heat exchanger.

### Components of the Direct Fired Vaporizer

The following diagram represents a cutaway view of a Direct Fired Vaporizer. This diagram includes all major component designations. Please note that this is a concept-drawing only, not a representation of the actual design.

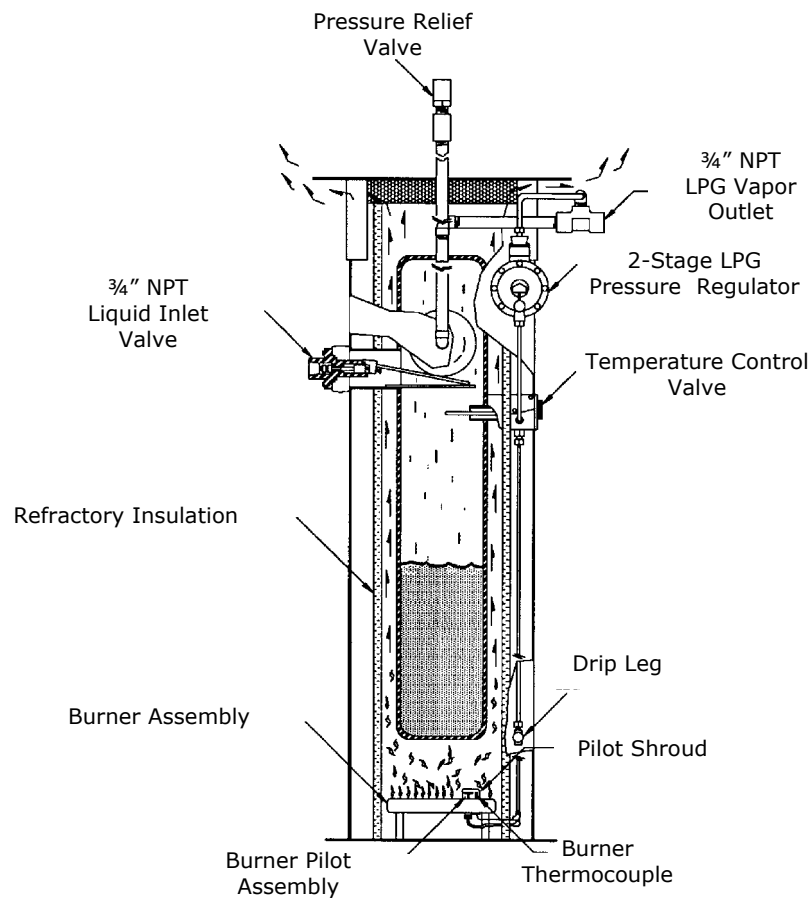

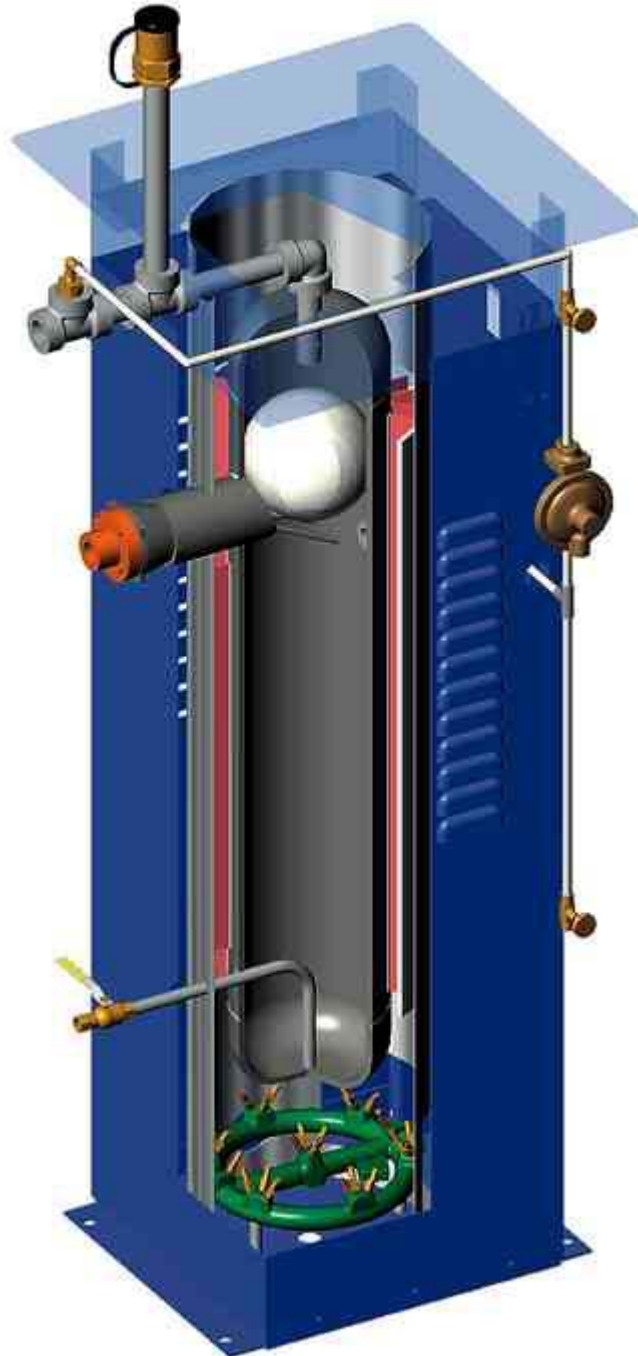

## VI. Installation

Certain procedures should be followed during installation. This chapter provides you with the step-by-step instructions necessary for effective and safe installation.

Before proceeding with the installation, please read the Summary of NFPA Requirements found at the end of Chapter III.

### Unpack and Anchor Unit

- Remove vaporizer from shipping container and take out the safety relief valve and pipe that are attached to the shipping skid.

Connect safety relief valve to unit using approved pipe sealant.

**IMPORTANT:**

Never use the safety relief valve pipe as a handle to move the vaporizer, etc.



- Place the vaporizer on a level concrete platform. The vaporizer base has a hole in each corner, through which anchoring bolts may be affixed. Remember that the unit must be installed at least 10 feet away from the LP Gas storage tank (see Chapter III).



### Install the Outlet Piping

- Install an extra heavy pipe union to the LPG outlet pipe.



- Install a UL listed shutoff valve with a minimum rating of 250 psi gas pressure. Either a globe valve or a ball valve may be used.



- Install a pounds to pounds pressure regulator. The regulator should be installed as close to the unit as possible (e.g. within several feet). If the regulator is installed at too great a distance from the unit, it is possible for the hot gas traveling along the line to cool back into a liquid state.

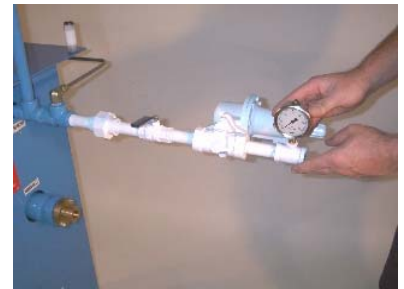

The vaporizer is now ready to be connected to the load for which the heated and vaporized LPG is being provided.

### Install the Inlet Piping

- Install an extra heavy pipe union to the LPG inlet valve.



- Install a "Y" (i.e. pipeline) strainer (see Maintenance - Chapter VII regarding periodic strainer cleaning).

**NOTE:**

In new pipe installations, the strainer should be removed and cleaned after approximately the first hour of operation. This is necessary to remove residue and other materials which may accumulate as a result of the new installation.



- Install a UL listed shutoff valve with a minimum rating of 250 psi gas pressure.



The vaporizer is now ready to be connected to the LP Gas container.

### Typical Installation Configuration

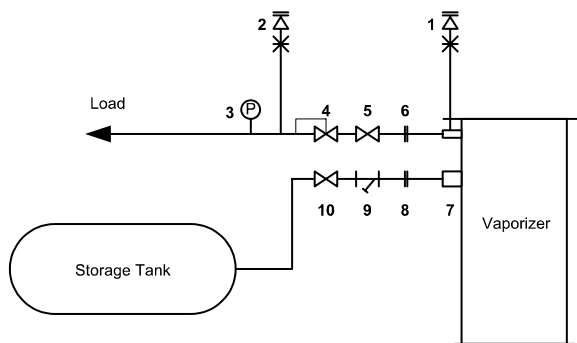

- 1 Pressure Relief Valve
- 2 Pressure Relief Valve
- 3 Pressure Gauge
- 4 Service Pressure Regulator
- 5 Vapor Shutoff Valve
- 6 Union, Vapor Line
- 7 Liquid Inlet Valve
- 8 Union, Liquid Line
- 9 Liquid Inlet Strainer
- 10 Liquid Shutoff Valve



## Test the System for Gas Leaks

- Ensure outlet valve is closed.



- Open inlet valve slowly.  
Pressure will equalize inside the unit.



- Place a solution of soapy water liberally around all threaded and welded pipe joints, tube fittings, and the like.



- Check all pipe and tube joint connections for evidence of gas leakage.  
**Correct any leakage found before proceeding further.**

## Test the System for Correct LPG Gas Pressure

- Open the burner valve.
- Check gas pressure by connecting a water column manometer or U-tube manometer to the drip leg. The pressure should measure approximately 11 (eleven) inches on the water column tube.

Repeat pilot pressure check when pilot is lit.



## Ignite the Gas Burner

- Upon starting, the black thermostat control knob (main selector valve) should be in the OFF position.  
  
The green temperature dial should be turned to its coldest setting (extreme clockwise position).
- Turn the black thermostat control knob (main selector valve) counter-clockwise to the PILOT position.
- While depressing the black knob, press the piezo igniter button several times until the pilot ignites. Continue to depress the black knob for approximately 60 seconds or until the pilot remains lit.

### NOTE:

If the vaporizer is equipped with the optional electric ignition, instead of pushing the piezo igniter button, turn on power to the igniter module.



- Check remaining lines connected to thermostat for gas leaks.
- Using a soapy solution, spray the lines coming from the thermostat burner control . . .



. . . and the pilot burner.



- Any leakage must be corrected before proceeding any further.
- Turn the black thermostat control knob (main selector valve) counter-clockwise from the PILOT position to the ON position.
- Turn the temperature dial counter-clockwise and set it to the HI position.

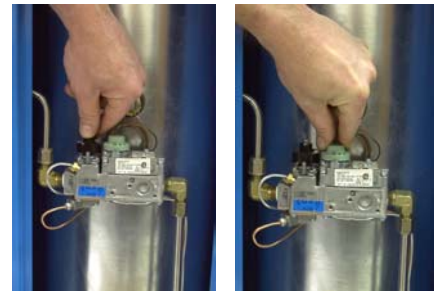

- Open the outlet valve slowly.

**NOTE:**  
Open the outlet valve only after the unit has reached normal operating temperature.

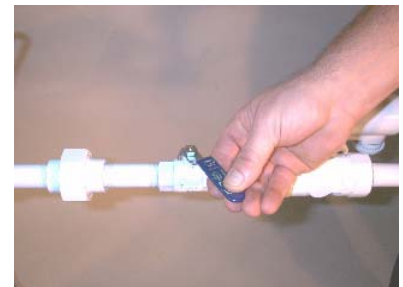

- Adjust outlet regulator to desired pressure.



- Set outlet pressure relief valve within a range of 125% to 250% of the regulator pressure setting.



The direct fired vaporizer is now fully operational.

### Typical Installation Configuration

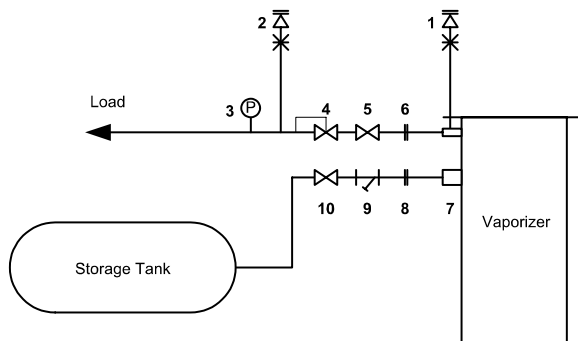

- 1 Pressure Relief Valve
- 2 Pressure Relief Valve
- 3 Pressure Gauge
- 4 Service Pressure Regulator
- 5 Vapor Shutoff Valve
- 6 Union, Vapor Line
- 7 Liquid Inlet Valve
- 8 Union, Liquid Line
- 9 Liquid Inlet Strainer
- 10 Liquid Shutoff Valve

## VII. Vaporizer Start-Up and Shut-Down

This chapter describes how to start the installed Direct Fired Vaporizer. It also describes how to set the controls for either on-going operation or for long periods of shut-down.

### Starting the Direct Fired Vaporizer

The following describes the procedure for starting the direct fired vaporizer.

- Inspect all fittings and connections for gas leaks.
- Any leakage must be corrected before proceeding any further.



- Close the vapor hand valve, located on the 3/4" vapor outlet.

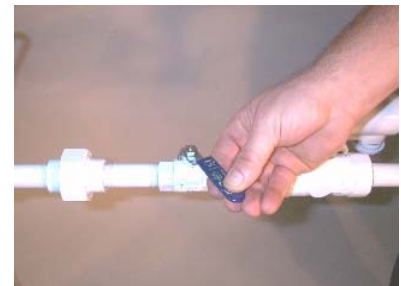

- Open the liquid inlet valve slowly.



- Turn the green temperature dial to its coldest setting (extreme clockwise position).
- Turn the black thermostat burner control knob clock-wise to the PILOT position.



- While depressing the button, press the piezo igniter button several times until the pilot ignites.

**NOTE:**

The button must remain depressed for 30 to 60 seconds until the pilot light remains lit. If the vaporizer is equipped with the optional electric ignition, instead of pushing the piezo igniter button, turn on power to the igniter module.



- Turn the black thermostat burner control knob counter-clockwise from the PILOT position to the ON position.
- Turn the green temperature dial counter-clockwise and set it to the HI position.



- Check all gas connection for leaks.



### **Control Settings for On-Going Operation**

The following describes the control settings for use during on-going operation (vaporizer was started as described in Chapter VII and then shut down, with the pilot staying lit).

- Verify that the pilot is still lit.
- Turn the black burner control knob counter-clockwise from the PILOT to the ON position. Leave the temperature dial in the HI position. This will turn the main burner ON.
- After burner shuts off and pilot remains lit, open the vapor hand valve, located on the 3/4" LPG vapor outlet.

**NOTE:**

Open the outlet valve only after the unit has reached normal operating temperature (burner cycle completed).

### **Control Settings for Long Periods of Shut-Down**

Depending upon the application for which the direct fired vaporizer is being used, the season of the year, etc., you may decide to shut the unit down for a significant period of time.

When the vaporizer is to be shut down, we highly recommend that the pilot light be left on. Allowing the pilot light to remain lit through long periods of inactivity keeps certain parts of the unit dry, while other parts remain lubricated. As a safety precaution, all units are equipped with an automatic safety device to shut off the flow of gas to the main burner and the pilot burner if the pilot light is extinguished.

The simple shut-down procedure is as follows:

- Close the vapor outlet valve.
- Turn the black burner control knob clockwise from the ON position to the PILOT position.
- Ensure that the liquid inlet valve remains open (closing this valve cuts off the fuel supply to the pilot light) during the entire shut down period.
- Ensure that all valves between the liquid inlet valve and the fuel source remain open during the entire shut down period.

### **Complete Shut-Down**

- Allow burner to come up to temperature and shut off. Pilot will remain lit.
- Turn the black burner control knob to the OFF position. Verify that the pilot light is extinguished.
- Turn the green temperature dial to the extreme clockwise (lowest temperature setting) position.
- Close the liquid inlet hand valve and the vapor outlet valve.
- Bleed residual vapors in the vaporizer to a safe area after verifying that all open flames are extinguished.



## VIII. Maintenance

This chapter includes both periodic and as-needed maintenance procedures.

### Periodic Maintenance Procedures

#### Weekly

Clean pilot light openings. Adjust flame so that 1/2" of the thermocouple tip is enveloped in flame. Run the vaporizer. Turn off pilot, and inspect to make certain the flame is extinguished. Drain heavy ends from the burner train drip leg. Re-light the pilot light and re-start the vaporizer.

#### Monthly

Turn off pilot, and inspect to make certain the flame is extinguished. Clean the pipeline strainer at the inlet piping. Re-light the pilot light and re-start the vaporizer.

#### Annually

Wash heavy ends from the unit. Refer to "Procedure for Washing Heavy Ends" as described below.

Turn off pilot and close the liquid inlet valve. Open vapor outlet valve and bleed the contained vapors to a flare or to a safe area. Replace the regulator seat. Clean the liquid inlet valve. Clean or replace the pipeline strainer at the inlet piping. Clean burner openings. Inspect and replace the thermocouple if necessary. Clean the thermostat. Clean out flue by using compressed air. Re-light the pilot light and re-start the vaporizer.

### Procedure for Washing Heavy Ends

Normally, LPG is a clean fuel. But there are certain times when there is a concentration of heavy ends such as oil or sulfur, and sometimes, thick grease may be in the LPG. These heavy ends are soluble in liquid LPG and drop out at the vaporization point. Should this happen, the vaporizer will lose some of its vaporizing efficiency. It is then necessary to remove the vaporizer from service for draining.

The procedure below applies to each heat exchanger in the system. It is to be followed on an as-needed basis.

- Start the vaporizer following the procedure described in this manual. Allow the unit to reach normal operating temperature. After reaching normal operating temperature, the burner will automatically turn off and return to the pilot light only. After the pilot light only is on, turn the black burner control knob clockwise to the OFF position.





- Inspect the unit and make certain all flame is extinguished before going on to the next step.
- Make certain NO sources of ignition are present.
- Open the vaporizer's Manual Drain Valve.
- The pressure inside the vaporization tube will force any heavy ends, which may have collected at the bottom of the vaporization tube, out. It will only be necessary to open the valve very briefly to allow all contamination to exit the vaporization tube.
- Collect heavy ends in a suitable container and dispose of them in accordance with applicable environmental laws and regulations.
- Perform "Procedure for Removal of Heavy Ends from Burner Regulator Drip Leg" as described below.
- Re-start system following the procedures in this manual.



**CAUTION:**

When opening the manual drain valve, LPG and any contamination will exit the vaporization tube at the system (tank / pump) pressure. Direct the flow away from personnel and objects !

**Procedure for Removal of Heavy Ends from Burner Regulator Drip Leg**

The fuel supply line from the burner pressure regulator to the temperature control valve is equipped with a long drip leg. This drip leg is designed to collect heavy ends before they get to the temperature control valve, where they could cause it to malfunction. To clean the drip leg and remove collected contamination, follow this procedure:

- Remove seal plug from end of drip leg.
- Place suitable container under drip leg.
- Open needle valve and allow contamination to collect in container.
- Close needle valve and re-install seal plug.
- Dispose of container and contents in accordance with applicable environmental laws and regulations.



## Gas Control Valve Maintenance

The temperature control valve (also known as gas control valve, gas valve, thermostat valve) is maintenance-free and does not have any serviceable parts.

If you suspect a malfunction of the temperature control valve, replace it with an identical valve, or with one approved by Alternate Energy Systems, Inc.

**USE ORIGINAL PARTS ONLY !!**  
**DO NOT REPLACE THE VALVE WITH A DIFFERENT TYPE !!**

## Gas Control Valve Replacement

- Vent all gas from the system to a safe area.

**NOTE:**

A safe area is a place with plenty of ventilation that is away from machinery or source of ignition such as a field or an open area. If there is no such area, it is recommended that a flare be installed to safely burn any gas that needs to be vented.

- Remove old valve.
- Replace with new valve.
- Re-start the unit according to the procedures described in this manual.

## IX. DF-Series

The DF Series direct fired vaporizers are comprised of more than one core unit of AE-80 or AE-120 heat exchangers, housed in a single compartment. The vaporizer model numbers are DF-1600, DF-2400, DF-3600, and DF-4800. The first three digits of the model number are a representation of the gallon per hour propane vaporization capacity at 0°F inlet temperature for each vaporizer (see *Appendix D – Glossary of Terms*). An appendix to the model number (i.e. DF-1600R or DF-1600F) indicates the make of the burner regulators and relief valves used on the vaporizer (R=REGO; F=FISHER).

### DF-Series Components

The following diagram represents a typical DF series direct fired vaporizer. Please note that, depending on model and application, the actual configuration may vary.

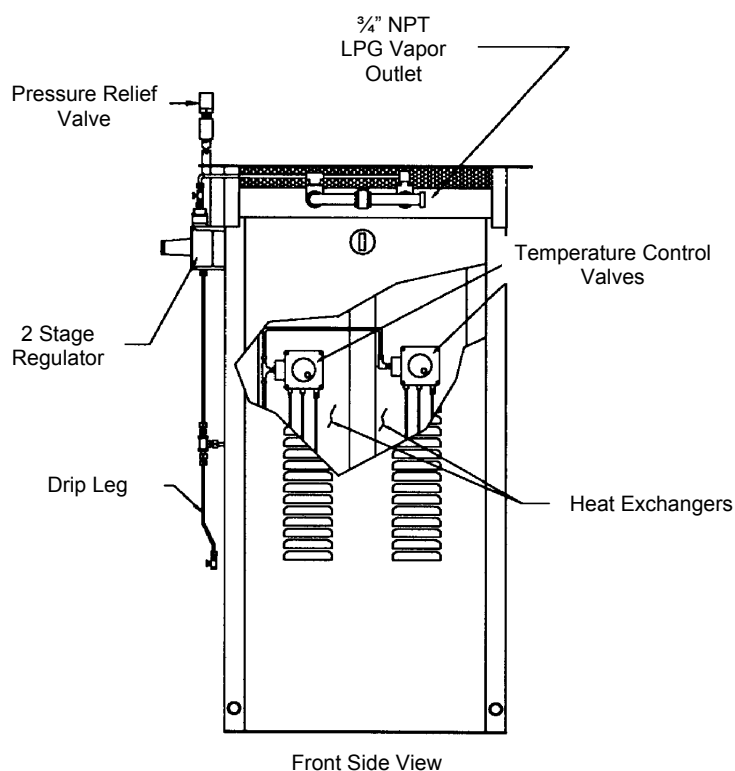

### DF-Series Procedures

When igniting the gas burners, the procedure as described above for the AE-series vaporizers must be repeated for each burner assembly.

When checking the burner and pilot fuel connection for leaks, repeat the procedure for each core unit.

## Appendix A – Telephone and Internet Assistance

If you have any questions regarding this manual or the installation of your vaporizer, you may call our technically trained customer service department at 770-487-8596. Our normal office hours are from 8:00 A.M. to 4:00 P.M. EST, Monday thru Friday.

Please be prepared to give us the model number and the serial number of your vaporizer when you call.

You can also submit your question or request for support via e-mail. The address for this is [aedfhelp@altenergy.com](mailto:aedfhelp@altenergy.com).

Our website at <http://www.altenergy.com> contains an updated version of this manual. Go to <http://www.altenergy.com/brochures.htm> to view and/or download the latest version.

## Appendix B – Trouble Shooting

Problem	Cause	Solution
Pilot Light won't stay lit	Pilot assembly clogged	Inspect and clean pilot assembly.
	Clogged pilot line	Remove pilot line from vaporizer. Remove any contaminants from the pilot line (i.e. with compressed air). Re-install pilot line on vaporizer; repeat procedure.
	Loose thermocouple Defective thermocouple	Check thermocouple fitting to determine if it is too loose or too tight. Tighten only enough to make good electrical contact. Verify that the tip of the thermocouple is fully enveloped by the pilot flame. While holding down the black main selector valve, check the pilot voltage with an appropriate instrument and adapter (i.e. ITT #500R106 Millivolt Meter and 17T#103050G Adapter). Reading should be approximately 14 mV. If reading is less than 6 mV, replace the thermocouple and repeat procedure.
	Defective Temperature Control Valve	Inspect and replace, if necessary.

<b>Problem</b>	<b>Cause</b>	<b>Solution</b>
Burner shuts off / main burner failure.	Pilot light failure.	See above steps.
	Faulty regulator.	Inspect and replace if necessary.
	Dirt / debris in LPG.	Inspect LPG supply. Clean pipeline strainer at inlet piping.
	Defective or dirty gas control valve (temperature control).	See "Gas Control Valve Maintenance" in Chapter VIII.
	LPG not entering vaporizer.	Inspect and open all valves from fuel source to burner to ensure proper fuel flow.

<b>Problem</b>	<b>Cause</b>	<b>Solution</b>
Liquid Carryover	Connected load exceeds vaporizer capacity.	Reduce load and/or install additional vaporizer (must be same size; see Appendix G for details).
	Heat transfer from the burner to the heat exchanger and/or to the LPG is insufficient.	Inspect burner and verify that all burner jets are working. Repair/replace if necessary.  Inspect heat exchanger.
	Residue buildup in heat exchanger.	If the LPG contains so-called 'heavy ends', they tend to settle at the bottom of the heat exchanger. The effective heat exchange area is reduced by the area that is covered by the heavy ends. Remove them, using the procedure described in Chapter VIII, Maintenance.
	First-Stage regulator too far away from vaporizer.	The first-stage regulator should be installed as close to the vaporizer as possible (see Chapter IV, Installation, Page 15). If the regulator is too far away, the hot vapor, which is still under higher pressure, may cool too much and may re-condensate (liquefy).

## Appendix C – Spare Parts

Performing periodic maintenance and troubleshooting will – from time to time – require the use of certain spare parts. We recommend that you keep the following spare parts and associated quantities in your inventory.

QTY	Part Description	Part Number						
		AE-50	AE-80	AE-120	DF-1600	DF-2400	DF-3600	DF-4800
1	Complete Burner Assembly (Propane)	BUR0006	BUR0015	BUR0015	BUR0015	BUR0015	BUR0015	BUR0015
(Includes: Burner, Pilot Light, Thermocouple, Piezo Spark Igniter)								
1	Complete Burner Assembly (Propane/Butane Mix)	BUR0006	BUR0019	BUR0019	BUR0019	BUR0019	BUR0019	BUR0019
(Includes: Burner, Pilot Light, Thermocouple, Piezo Spark Igniter)								
1	Burner (Propane)	BUR0005	BUR0001	BUR0001	BUR0001	BUR0001	BUR0001	BUR0001
1	Burner (Butane)	BUR0005	BUR0018	BUR0018	BUR0018	BUR0018	BUR0018	BUR0018
1	Complete Pilot Light Assembly	PIL0005	PIL0005	PIL0005	PIL0005	PIL0005	PIL0005	PIL0005
(Includes: Pilot Light, Thermocouple, Pilot Light Fuel Line)								
1	Thermocouple for Pilot Burner	THE0001	THE0001	THE0001	THE0001	THE0001	THE0001	THE0001
1	Piezo Spark Igniter	IGN0003	IGN0003	IGN0003	IGN0003	IGN0003	IGN0003	IGN0003
1	Two-Stage Burner Gas Regulator	REG0033* REG0021**	REG0033* REG0021**	REG0033* REG0021**	–	–	–	–
1	First Stage Regulator	–	–	–	REG0032 REG0023	REG0032 REG0023	REG0032 REG0023	REG0032 REG0023
1	Second Stage Regulator	–	–	–	REG0035 REG0022	REG0035 REG0022	REG0035 REG0022	REG0035 REG0022
1	Temperature Control Valve	TEM0003	TEM0003	TEM0003	TEM0003	TEM0003	TEM0003	TEM0003
1	Liquid Inlet Valve Assembly	LIQ0001	LIQ0001	LIQ0001	LIQ0001	LIQ0001	LIQ0001	LIQ0001
(Includes: Viton® O-Ring, Viton® Seat Seal)								
2	Viton® Seat Seal for Liquid Inlet Valve	LIQ0005	LIQ0005	LIQ0005	LIQ0005	LIQ0005	LIQ0005	LIQ0005
2	Viton® O-Ring for Liquid Inlet Valve	ORI0002	ORI0002	ORI0002	ORI0002	ORI0002	ORI0002	ORI0002
1	Door (burner cover) for Burner Shroud	SHR0005	SHR0005	SHR0005	SHR0005	SHR0005	SHR0005	SHR0005
* for AE-XXGR models, order REG0032 for 1 <sup>st</sup> Stage Regulator, and REG0035 for 2 <sup>nd</sup> Stage Regulator ** for AE-XXGF models, order REG0023 for 1 <sup>st</sup> Stage Regulator, and REG0022 for 2 <sup>nd</sup> Stage Regulator								

When ordering parts from AES, please remember to include the model number and the serial number of your Direct Fired Vaporizer.

You may order any of these parts from your distributor/installer, or directly from us at:

Alternate Energy Systems, Inc.  
Post Office Box 2469  
210 Prospect Park  
Peachtree City, Georgia 30269, USA  
Phone 770-487-8596  
Telefax 770-631-4306  
Toll Free 800-410-9161  
E-Mail [parts@altenergy.com](mailto:parts@altenergy.com)

Additional spare parts and a price list can be found on our website at  
<http://www.altenergy.com/Pricelists/pricelis.htm>.

## Appendix D – Glossary of Terms

**ASME** – American Society of Mechanical Engineers.

**AE - 50** – 50 gallon per hour direct fired vaporizer (may have suffix R, F, GR, or GF; see below).

**AE - 80** – 80 gallon per hour direct fired vaporizer (may have suffix R, F, GR, or GF; see below).

**AE - 120** – 120 gallon per hour direct fired vaporizer (may have suffix R, F, GR, or GF; see below).

**AE - XXX G** – G-versions of above models for extreme climates (only available in Canada and Minnesota)

**AE - XXX R** – Vaporizers with REGO regulators and relief valves

**AE - XXX F** – Vaporizers with FISHER regulators and relief valves

**Air Louvers** – Supply combustion air for the impingement burner.

**Ball Valve** – Hand operated manual shutoff valve.

**Burner Shroud** – Galvanized metal shroud covering the outer surface of the heat exchanger.

**Burner Main Drip Leg** – Collects heavy ends from the vapor fueling the burner.

**Burner Valve** – Controls the pilot, main burner and the outlet temperature of the vaporized LP-Gas.

**DF - 1600** – 160 gallon per hour direct fired vaporizer (may have suffix R, F, GR, or GF; see above).

**DF - 2400** – 240 gallon per hour direct fired vaporizer (may have suffix R, F, GR, or GF; see above).

**DF - 3600** – 360 gallon per hour direct fired vaporizer (may have suffix R, F, GR, or GF; see above).

**DF - 4800** – 480 gallon per hour direct fired vaporizer (may have suffix R, F, GR, or GF; see above).

**Direct Fired Vaporizer** – A vaporizer in which heat furnished by a flame is directly applied to some form of heat exchange surface in contact with the liquid LP-Gas to be vaporized. This classification includes submerged-combustion vaporizers.

**Factory Mutual Installation** – An installation of LP-Gas equipment that is in accordance with all the applicable provisions of the Factory Mutual Research Code.

**Flue** – A passageway producing a draft effect to permit the products of combustion to go to atmosphere.

**Gallon** – U.S. Standard. 1 U.S. Gallon = 0.833 Imperial gal = 231 cu in. = 3.785 liters.

**Globe Valve** – A positive shut-off valve for liquid or vapor service.

**Heavy Ends** – The residual oils that are extracted from LP-Gas when heat is applied to liquid or vapor.

**Industrial Risk Insurers Installation** – An installation of LP-Gas equipment that is in accordance with all the applicable provisions of the Industrial Risk Insurers (IRI) code.

**Inlet Pipe** – An ASTM A106 or A53 (ASME: SA106 or SA53) grade of Schedule 80 pipe for piping from the storage tank to the inlet of the LP-Gas vaporizer.

**Inlet Valve** – A heavy duty bronze valve designed to limit the level of LP-Gas in the vaporizer.

**Liquid Level Control** – Prevents Liquid LP-Gas carryover from the vaporizer.

**LPG, LP-Gas** – Liquefied Petroleum Gas.

**Manometer** – Measures low pressure LP-Gas, usually in inches of water column.

**NFPA 58** – National Fire Protection Association Pamphlet No. 58. In the United States, all LP-Gas equipment must be manufactured and installed in accordance with the provisions of this code.

## Appendix D – Glossary of Terms (continued)

- Outlet Pipe** – An ASTM SA106B or SA53B grade of Schedule 80 pipe for piping from the outlet of the vaporizer to the user's process.
- Outlet Pressure Relief Valve** – Located downstream of the outlet pressure regulator, the valve is designed to open at a pre-determined setpoint to prevent the rise of pressure in excess of the specified inlet pressure rating of downstream valves and regulators.
- Outlet Pressure Regulator** – Located at the outlet of the vaporizer, the regulator reduces the LP-Gas vapor from the storage tank's pressure to the user's required pressure.
- Outlet Valve** – Positive shut-off valve designed to isolate the vaporizer at the vapor discharge point.
- Piezo Igniter** – When depressed, this device creates a spark which lights the direct fired burner.
- Pilot** – A small constant burning flame on the burner, used to ignite the main burner on a call for heat.
- Pipe Union** – A forged steel black pipe fitting, used in pipe lines to allow for removal of valves, controls, vaporizers, etc.
- Pounds to Pounds Pressure Regulator** – A pressure regulator that reduces a high pressure (i.e. 120 psig) to a lower pressure (i.e. 20 psig).
- Pressure Regulator** – A device that reduces pressure from pounds to pounds, pounds to inches of water column, or inches to inches.
- LPG Vapor Outlet** – The connection point at the discharge opening of the LP-Gas vaporizer.
- PSI, PSIG** – Pounds per square inch, pounds per square inch gauge, respectively.
- Refractory Fiber Insulation** – A ceramic insulation that covers the heat exchanger to minimize heat loss.
- Safety Relief Valve** – A pressure-relieving device, designed to discharge to atmosphere excessive pressures in the heat exchanger.
- Shutoff Valve** – Isolates LP-Gas equipment and/or stops the flow of LP-Gas through the equipment.
- Stationary Installation** – An installation of LP-Gas containers, piping and equipment for use indefinitely at a particular location; an installation not normally expected to change in status, condition or place.
- Storage Tanks** – Large cylindrical steel vessels where the LP-Gas is stored for usage.
- Temperature Control Valve** – A gas flow control valve with ON/OFF characteristics, designed to maintain the temperature of the vaporized LP-Gas at a pre-determined setpoint.
- Thermocouple** – Monitors the pilot flame and shuts off the control valve in the event of loss of pilot.
- U-Tube Manometer** – A pressure measuring device, utilizing water (sometimes colored water) in a "U" tube configuration to measure pressure in inches of water column.
- Unload Stations** – A specified area with proper valves and connections, where transport or bobtail trucks unload LP-Gas into the storage tanks.
- Unloading Connections** – Connection points at the unloading station, where the transport or bobtail trucks connect their liquid and vapor hoses to unload their product into the storage tanks.
- Vaporizer** – A device which receives LP-Gas in liquid form and adds sufficient heat to convert the liquid to a gaseous state.
- Vaporizer Tube, Vaporization Tube** – The heat exchanger where the liquid is converted to a vapor.
- Y Strainer** – A device used in piping systems to remove heavy particles from the LP-Gas.



---

## Appendix E – Electric Re-Igniters

All models of the Direct Fired Vaporizers can be equipped with an optional electric re-igniter. Powered by either a normal 9V-battery or by AC 110 V line power, this option replaces the standard push-button piezo igniter.

Both versions generate a high-voltage spark to the pilot burner, igniting the LPG vapor coming through the pilot burner nozzle. When a pilot flame is established, the sparking stops. It resumes automatically, when the pilot flame extinguishes.

As long as the safety thermocouple at the pilot burner is still “hot”, allowing gas flow from the temperature control valve to the pilot burner, and as long as there is sufficient electric power, the pilot light will re-light automatically.

In vaporizers with multiple heat exchangers, each heat exchanger must be equipped with its own igniter.

### 9V Battery Operated Igniter

This option is designed for installations where electric line power is not available, or where the line power is incompatible with the AC version of the electric re-igniter.

The solid state igniter uses a standard 9V block battery to light the burner, monitor the flame, and to re-light the burner if necessary. A small push button on the front of the vaporizer turns battery power to the igniter on. An Alkaline battery may last for approximately 500 hours, or 10,000 sparks of operation. The battery should be replaced every two years, or as needed.

The module emits a “clicking” sound during lighting attempts (initially, or as the result of flame failure due to wind, or fuel run-out). This provides a way to monitor your vaporizer from the outside, without having to open the cabinet. If the flame goes out, the clicking sound will indicate that the igniter attempts to re-light the burner.

If the vaporizer is turned off completely, the clicking sound will also remind the operator to turn the power to the module off.

After the pilot light is established, leave the power switch in the ON position. If power to the igniter module is turned off, automatic re-ignition will not occur.

### AC 110 V 50/60 Hz Igniter

This option is designed for installations where electric line power is available at all times.

The igniter module is powered at all times. There is no ON/OFF switch at the vaporizer. If an ON/OFF switch is required, an external, fused disconnect should be used.

### WARNING:

**If pilot fails to ignite, turn gas off and wait at least one minute before repeating the start procedure.**

## Appendix F – Approvals

### 1. Reprint from the January 20032001 Factory Mutual Research Approval Guide

---

**2003  
APPROVAL GUIDE  
CHAPTER 7  
FLAMMABLE GAS EQUIPMENT  
VAPORIZERS**

These vaporizers are for outdoor use. They may be designed to vaporize liquid petroleum by direct-fired burners located under the vaporizing chamber(s) or by heating a water charge which surrounds the vaporizing coil. Rate of vaporization is automatically controlled to supply the demand of consuming devices with control provided by a thermostatic element installed in the vaporizing chamber. For fire protection reasons, the vaporizer should be located as far as practical from the liquid petroleum storage tank. The vaporizer should be at least 75 ft (23 m) from the tank relief valve and at least 15 ft (5 m) from any part of the tank. However, vaporizers for use with tanks of 2000 gallons (10 m<sup>3</sup>) water capacity or less may be located not less than 25 ft (8 m) from the tank relief valve. Further, it is recommended that the manufacturer always be advised of the proposed installation when ordering a vaporizer so that the connecting piping, associated fittings, etc., may be economically but properly sized. If electrical ratings are not noted in the listing, electrical power is not required for equipment operation.

#### LP-Gas

##### Alternate Energy Systems 210 Prospect Pk Peachtree City GA 30269

Direct Fired Vaporizer. Models AE-30, -50, -80, -120, DF-1600, -2400, -3600, -4800\*. Model No. designates rated capacity in gal/hr at 0°F (-18°C) inlet temperature.

Horizontal Water Bath Vaporizer with Venturi Burner. Models WB-200, -250\*\*, -350. Model No. designates rated capacity in gal/hr at 0°F (-18°C) inlet temperature. Requires 115 V, 60 Hz, 1 phase power.

Horizontal Water Bath Vaporizer with Power Burner. Models WB-450, -550, -650, -750, -850, -1000, -1200, -1500, -1800, -2000, -2200, -2500, -3000, -3500, -4500, -5500. Model No. designates rated capacity in gal/hr at 0°F (-18°C) inlet temperature. Requires 230 V, 60 Hz, 1 phase power for models through WB-1800. All others use 460 V, 60 Hz, 3 phase power.

\*DF models similar to AE models previously Approved as discussed in FM Approval report S/N 26918, dated July 25, 1977 and JI 0F3H5.AF, dated March 23, 1981.

\*\*WB-250 identical to models WB-200, WB-350 except for capacity.

---

### 2. Canadian Standards Association, CSA Canadian Gas Association, CGA

Direct Fired Vaporizers of the AE-series and the DF-series have received approval from the Canadian Standards Association (CSA), including approval from Canadian Gas Association (CGA). They also carry Canadian Registration Numbers (CRN) for all Provinces and Territories as listed below.

Model Number	CRN Number
AE-50G	L7245.5C
AE-80G	L7247.5C
AE-120G	L7248.5C
DF-1600	same as AE-80G
DF-2400	same as AE-120G
DF-3600	same as AE-120G
DF-4800	same as AE-120G

## Appendix G – Installation of multiple Vaporizers in one Location

Multiple AES Direct Fired Vaporizers can be combined (“manifolded” together) to increase the overall capacity of an installation. However, all heat exchangers in a multi-heat exchanger installation must be of the same size.

If heat exchangers of different sizes are combined, the total vaporization capacity is calculated by multiplying the number of heat exchangers with the capacity of the smallest heat exchanger.

**Example:** If a model AE-80 (capacity 80 gph) is combined with a model AE-120 (capacity 120 gph), the total capacity is not 200 gph (80 gph + 120 gph), but 2 x 80 gph = 160 gph.

**Explanation:** Assuming that pipe lengths and pipe diameters are the same, the total load in an installation distributes evenly across all connected vapor sources.

By design, if an AES Direct Fired Vaporizer is overloaded, the liquid carryover protection will engage and prevent LPG to exit the heat exchanger.

In the example above, at a load of 160 gph, each vaporizer would carry 1/2 of the load (= 80 gph per vaporizer). If the load is increased further, beyond a total of 160 gph, the liquid carryover protection of the AE-80 will engage and shut that vaporizer down. This will shift the entire load to the AE-120, which, at that point, will also encounter an overload situation and will also shut down.

**Solution:** Always combine vaporizers with heat exchangers of the same size. AES Direct Fired Vaporizers utilize three different heat exchanger sizes:

Vaporizer Models	Heat Exchanger Model		
	AE-50	AE-80	AE-120
AE-50 / AE-50G	1 x AE-50		
AE-80 / AE-80G		1 x AE-80	
AE-120 / AE-120G			1 x AE-120
DF-1600		2 x AE-80	
DF-2400			2 x AE-120
DF-3600			3 x AE-120
DF-4800			4 x AE-120

Possible Combinations:

Vaporizer Model	can be combined with
AE-50 / AE-50G	AE-50/AE-50G only
AE-80 / AE-80G	AE-80/AE-80G, DF-1600
AE-120 / AE-120G	AE-120/AE-120G, DF-2400, DF-3600, DF-4800
DF-1600	AE-80/AE-80G, DF-1600
DF-2400	AE-120/AE-120G, DF-2400, DF-3600, DF-4800
DF-3600	AE-120/AE-120G, DF-2400, DF-3600, DF-4800
DF-4800	AE-120/AE-120G, DF-2400, DF-3600, DF-4800

**Alternate Energy Systems, Inc.**

P.O. Box 2469

210 Prospect Park

Peachtree City, GA 30269, USA

Phone 770-487-8596

Fax 770-631-4306

E-mail [info@altenergy.com](mailto:info@altenergy.com)

Internet <http://www.altenergy.com>